

Тодорка Николова Николова
Силвия Маркова Гърневска
Светла Костова Ананиева
Валентин Георгиев Ананиев

1.

ТЕХНОЛОГИИ И ПРЕДПРИЕМАЧЕСТВО

за първи клас

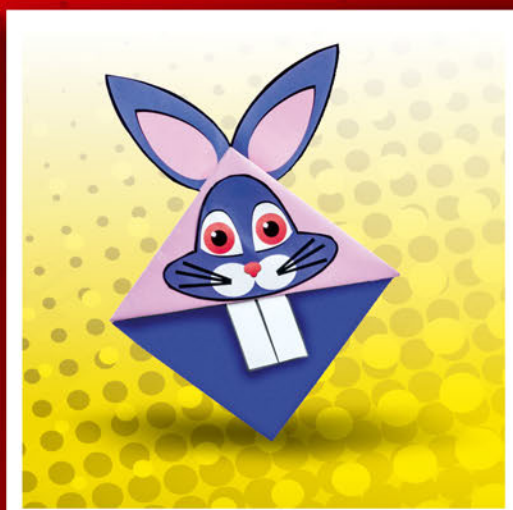

Тодорка Николова Николова
Силвия Маркова Гърневска

Светла Костова Ананиева
Валентин Георгиев Ананиев

ТЕХНОЛОГИИ И ПРЕДПРИЕМАЧЕСТВО

за първи клас



ТЕХНОЛОГИИ И ПРЕДПРИЕМАЧЕСТВО

за първи клас

Автори: доц. д-р инж. Тодорка Николова Николова
гл. ас. д-р инж. Силвия Маркова Гърневска
инж. Светла Костова Ананиева
инж. Валентин Георгиев Ананиев

Художници: Живко Иванов Рухов,
Катерина Иванова Милушева

Рецензенти: проф. д-р Тодорка Жекова Стефанова, РУ „Ангел Кънчев“,
преподавател по методика на обучението
по технологии и предприемачество
Бояна Йорданова Пенева, гр. Варна, СОУ „Ал. С. Пушкин“,
начален учител

Редактор инж. Валентин Ананиев
Коректор Зоряна Стоянова

Българска. Първо издание.
Формат 60x90/8.
Печ. коли 5,5
Издателство „Бит и техника“ ООД,
Варна 9009, ул. „Кап. Райчо Николов“ №101

ISBN 978 - 954 - 9412 - 53 - 6

- © Тодорка Николова Николова, 2016
- © Силвия Маркова Гърневска, 2016
- © Светла Костова Ананиева, 2016
- © Валентин Георгиев Ананиев, 2016
- © Живко Иванов Рухов – корица, илюстрации и графичен дизайн, 2016
- © Катерина Иванова Милушева – илюстрации, 2016
- © Издателство „Бит и техника“ ООД, всички права запазени, 2016

Мило първокласниче,

Светът около теб е голям и интересен – небе, слънце, звезди, растения и животни... Това е природата, която е съществувала на Земята и преди появата на човека. Наоколо има и много други неща, които не се срещат в природата, а са направени от хората – сгради, автомобили, мебели...

Как от дървесината да се направи стол, от плата – дреха, а от хартията – книга? На това ни учи технологията. А предприемчивите хора изобретяват и правят все по-нови, по-интересни и полезни неща.

Затова твоят учебник се казва „Технологии и предприемачество“. С него през годината ти ще се научиш да изработваш от различни материали много красиви и полезни изделия за учебната дейност и игрите. Едновременно с това ще се научиш да обмисляш, планираш и организираш работата си така, че всичко да се случва по-добре, по-бързо и с по-малко средства.

От авторите

ОРИЕНТИРАНЕ В УЧЕБНИКА



Обяснение



Беседа, дискусия



Изработване



Задача



Наблюдение,
опит



Работа в екип



Внимавай при работа
с инструменти!



Самооценка

Указания за учителя

- Нови знания
- Затвърдяване, обобщение
- Диагностика

10



Кои части на растенията се използват от хората за храна? Огради ги.

Нови понятия
• хранителен продукт



Кои дейности са необходими за приготвяне на салатата? Номерирай ги по реда на извършването им.

СЪДЪРЖАНИЕ	стр.	стр.	
1. Знаем и мога от детската градина	4	17. Светът на машините – спортна кола	25
2. Моето работно място – табелка	5	18. Работа с прежда – мартеници	26
3. Работа с хартия – книгоразделител	6	19. Хартиени ролки – герданче	27
4. За Деня на народните будители – знамена и флагчета	7	20. Опаковка за подарък – торбичка и етикет	28
5. Работа с картон – седмична програма	8	21. Пролетна украса – цветя и пеперуди	29
6. От природни материали – есен	9	22. Грижи за растенията – проект „Осинови растение“	30
7. Хранителни продукти – чинийка от хартия	10	23. За празника на буквите – покана	32
8. Моите потребности – дърво на желанията	12	24. Великден – кошничка	33
9. Електричеството у дома – електрическа змия	14	25. Техника и технологии – лунна станция	34
10. Да пестим енергията – табелки с правила	15	26. Професии – моден дизайнер	35
11. Моят личен бюджет – вълшебен портмоне	16	27. За деня на земята – групов проект „Омагьосаната гора“	36
12. За Коледа и Нова година – картичка	18	28. Играчките на децата – Джетмен	37
13. Многослойно изрязване – снежинки	19	29. В супермаркета – блокче за бележки	38
14. Весела работилница – украса за елхата	20	30. Стоки и услуги – игра „На пазар“	39
15. За домашния любимец – куче и коте	22	31. Комуникации – шифровъчен кръг	40
16. Колелата в техниката и бита – акробат	24	32. Какво научих в първи клас	42

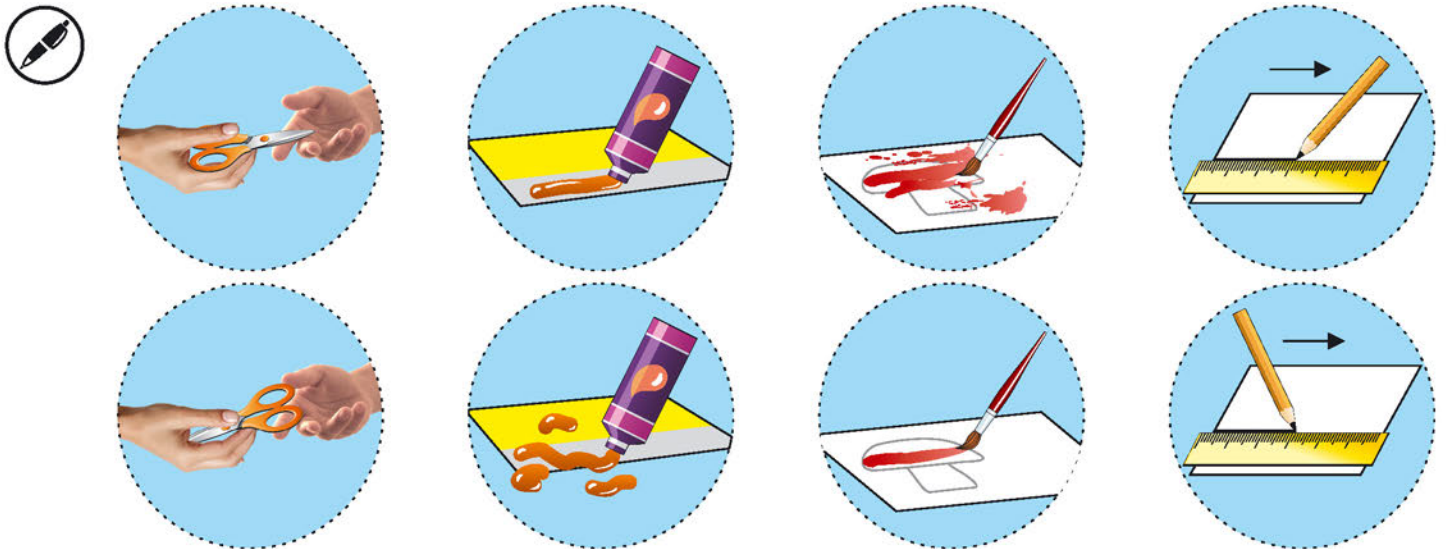

За какво се използват показаните материали и инструменти? Свържи всеки от тях със съответната картинка.

Огради картинките, показващи правилните и безопасни начини за работа с инструментите и материалите.

Отбележи със знак „✓“ предметите, направени от човека.



МОЕТО РАБОТНО МЯСТО

Табелка

2



АЛБУМ
Пр. 13

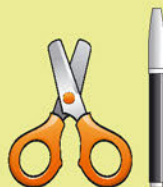

ИЗДЕЛИЯ



МАТЕРИАЛИ

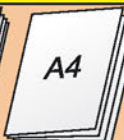
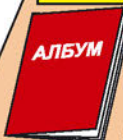

ИНСТРУМЕНТИ

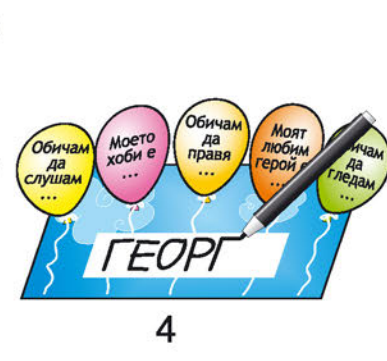
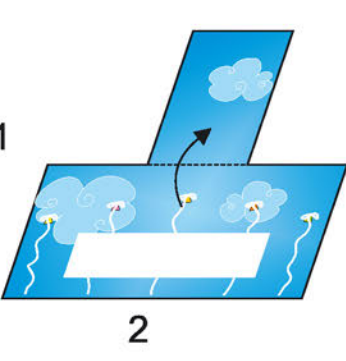
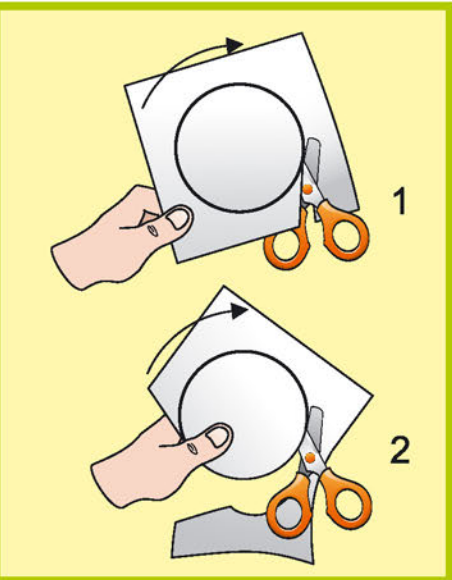
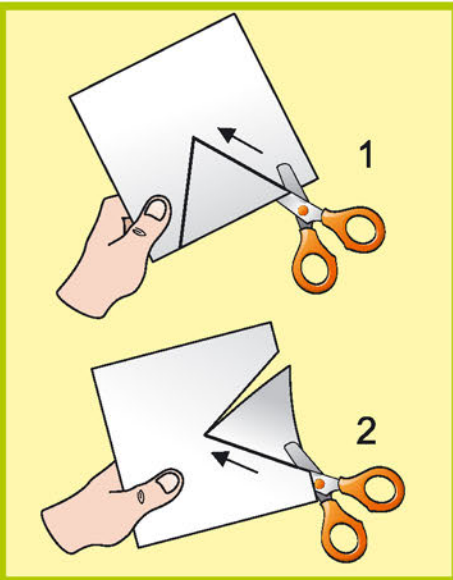
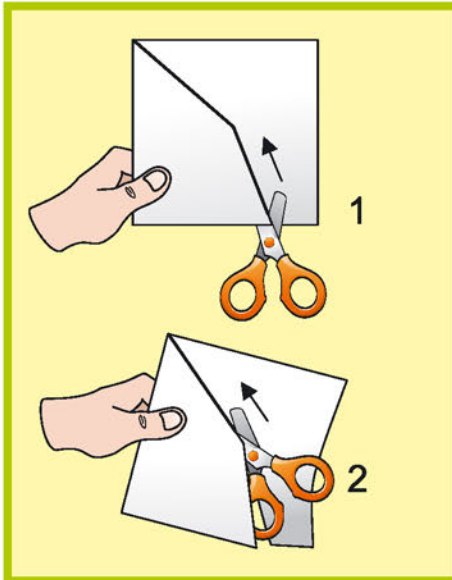
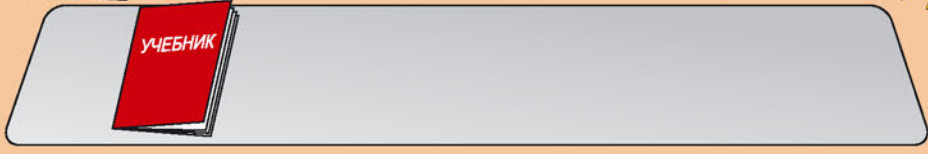

Как подреждаш работното си място?

Начини за изрязване по права и крива линия

Направи табелка с твоето име. Разкажи на съучениците си за своите желания, предпочитания и интереси (любими приказка, музика, филм, спорт, хоби и други).

- Нови понятия
- работно място
 - материали
 - инструменти
 - изделия
 - неподвижно съединяване

5



РАБОТА С ХАРТИЯ

Книгоразделител

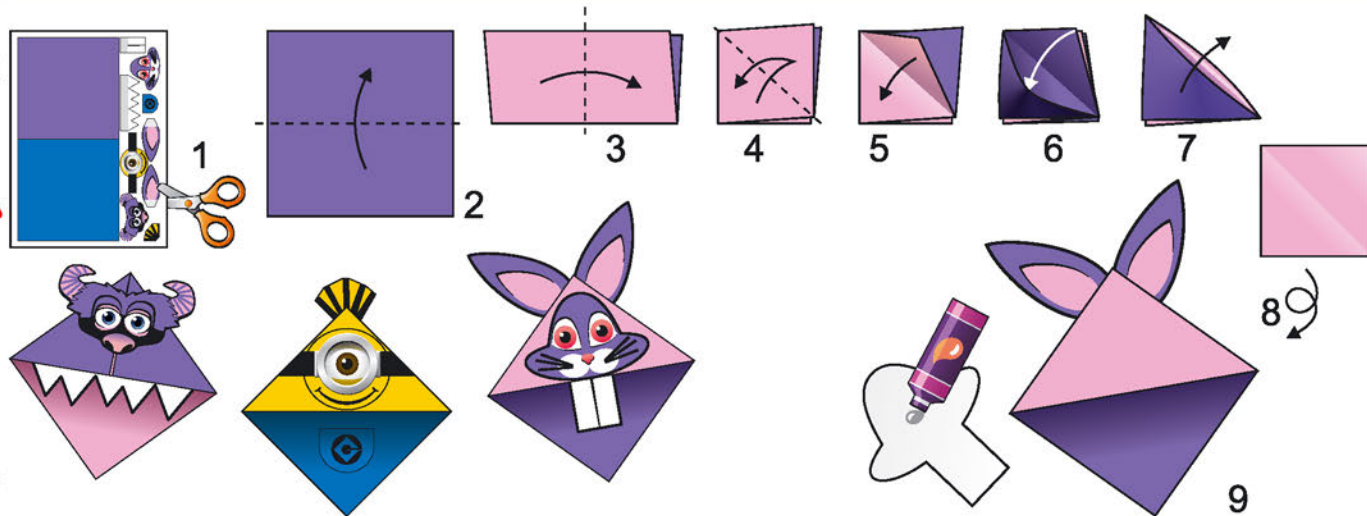
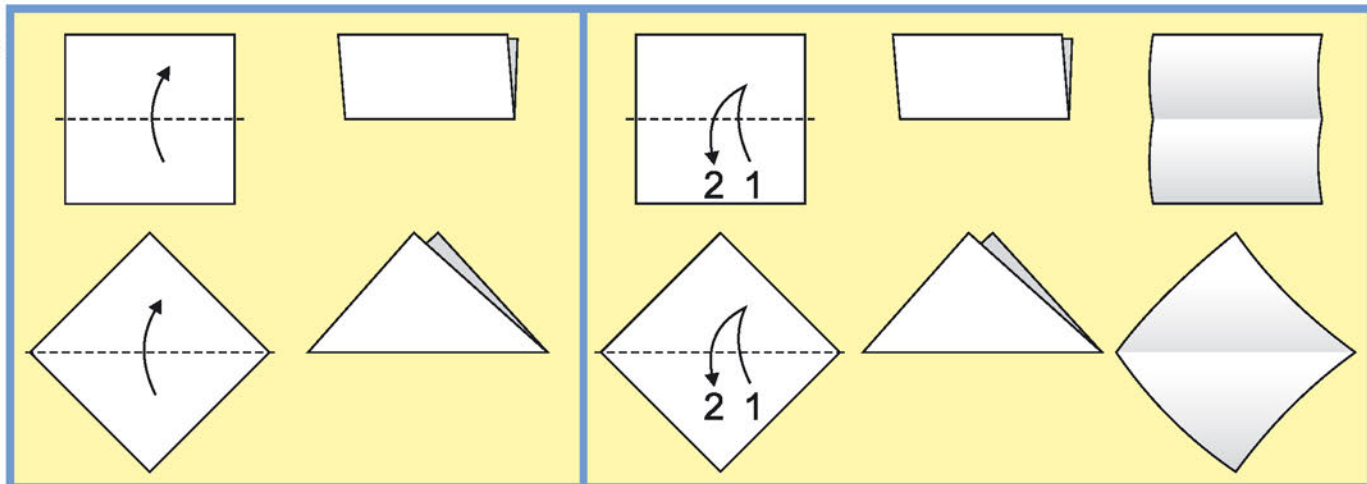
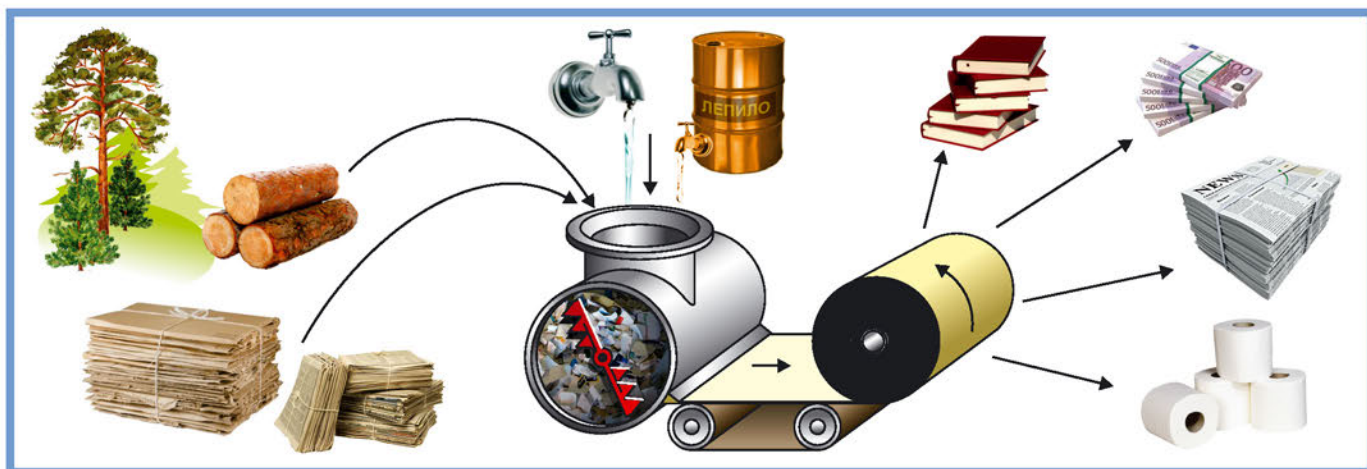
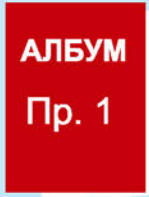

? От какво се получава хартията и за какво се използва?

6

☀ Начини за прегъване на хартия

✋ Направи книгоразделител.

ЗА ДЕНЯ НА НАРОДНИТЕ БУДИТЕЛИ

Знамена и флагчета

4

АЛБУМ
Пр. 2

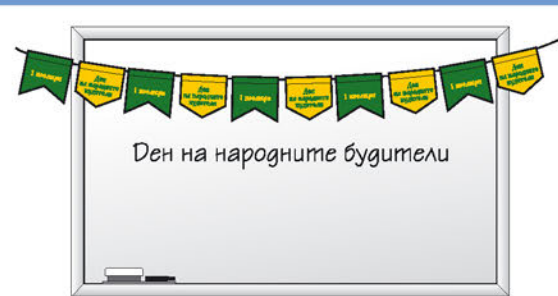
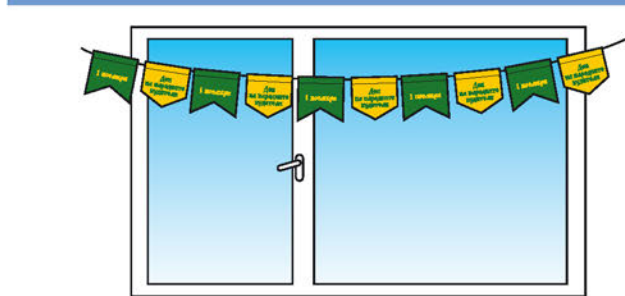
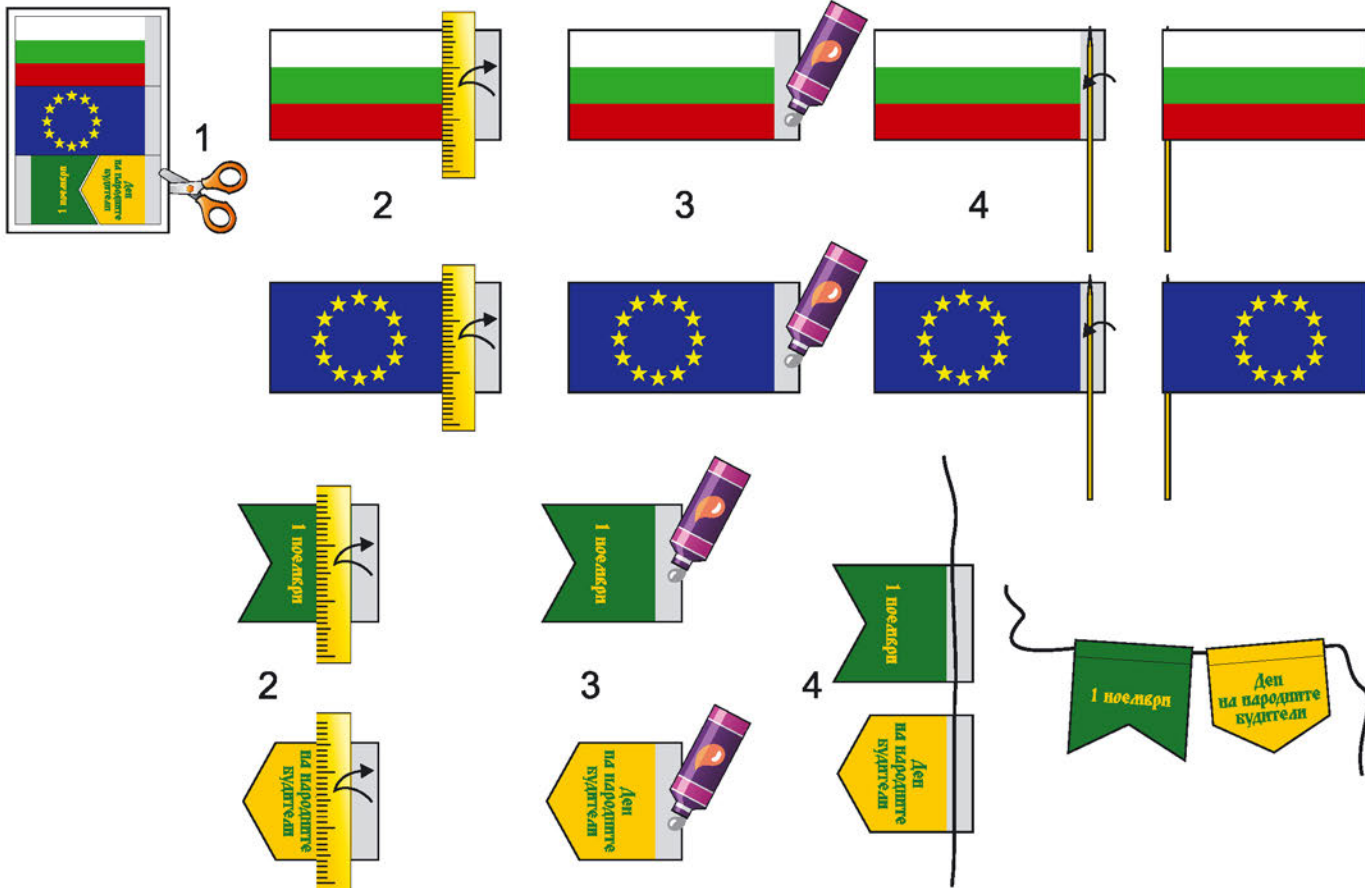
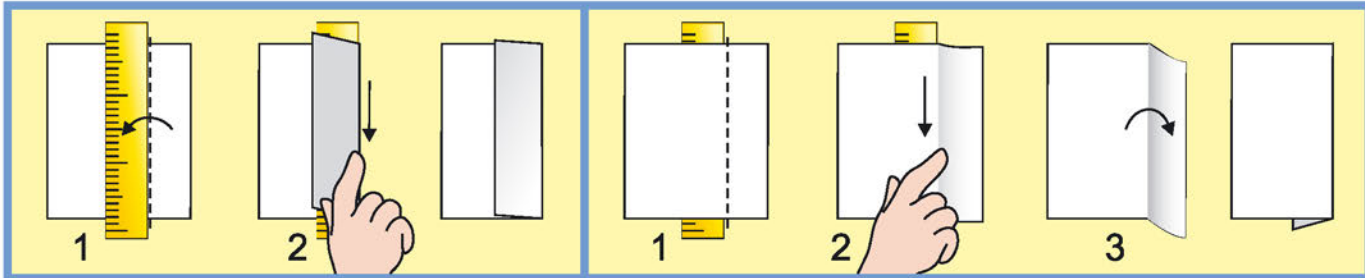

- Начини за прегъване на хартия
- Направи знамена и флагчета.
- Украсете класната стая със знамена и флагчета.

7



АЛБУМ

Пр. 8
Пр.14

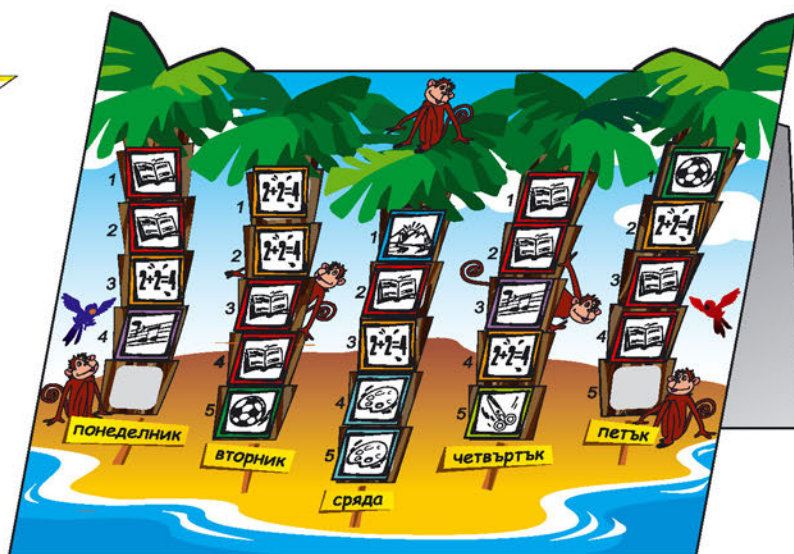
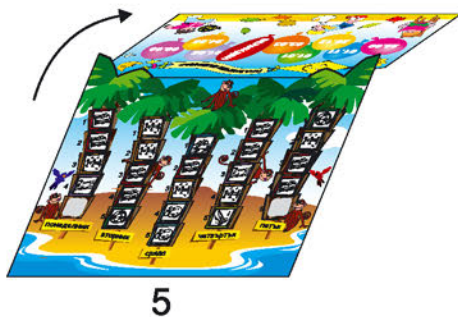
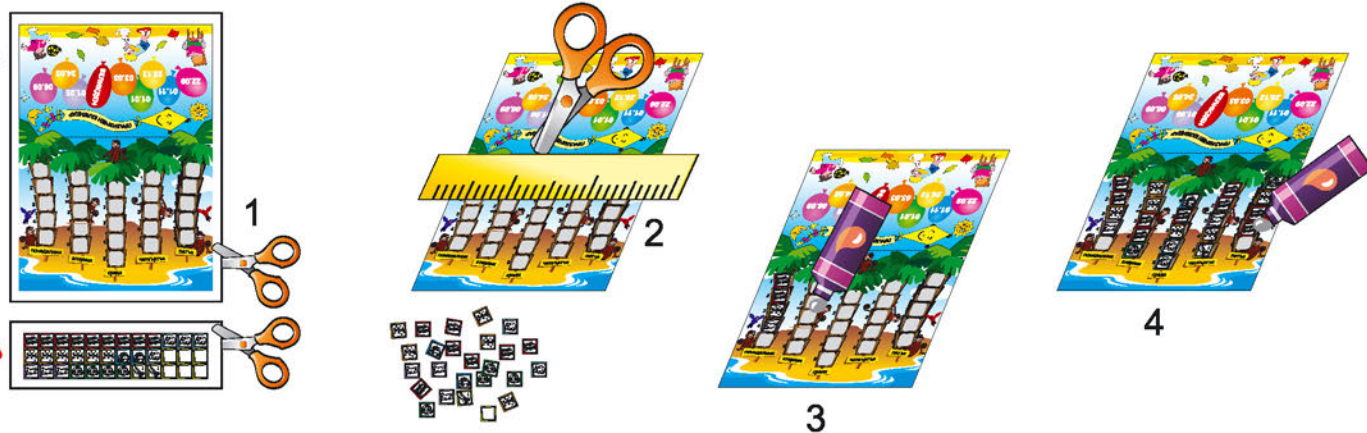
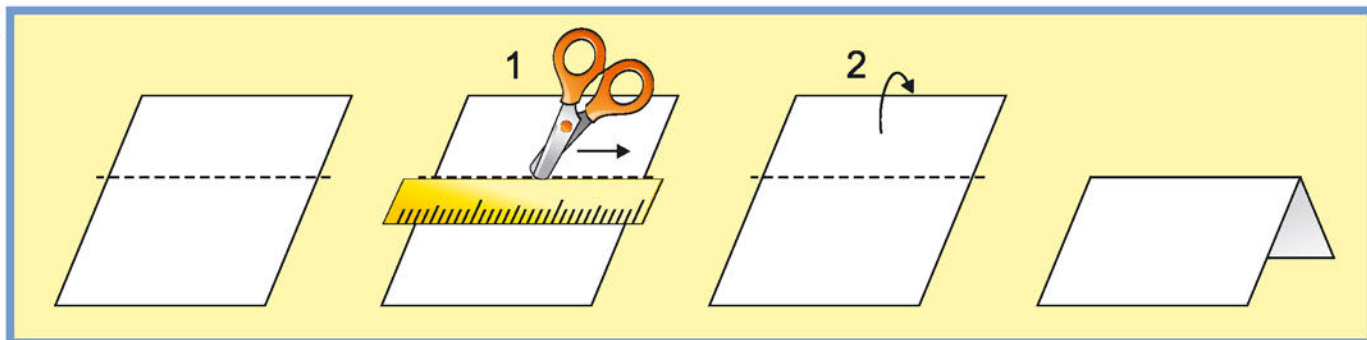

Начин за прегъване на картон

Направи седмична програма.

ОТ ПРИРОДНИ МАТЕРИАЛИ

Есен

6

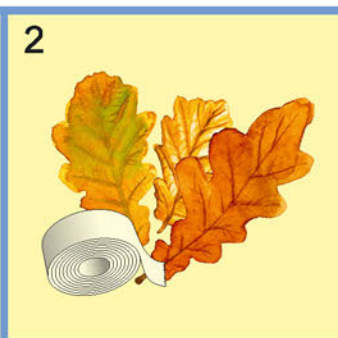
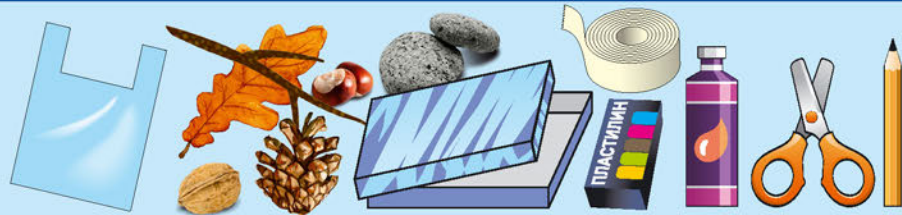

 Начини за закрепване на природни материали

 Направи макет диорама „Есен“ от природни и подръчни материали, като предварително определиш местата за закрепване на отделните елементи.

9



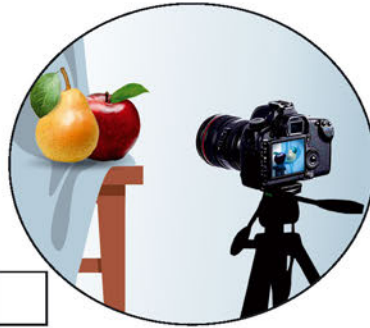

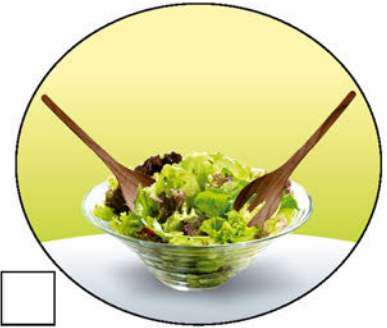



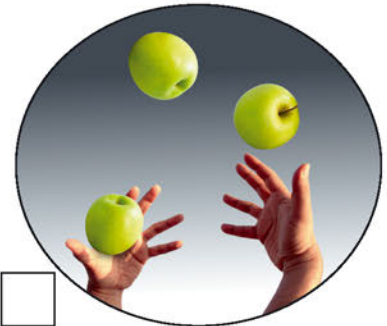

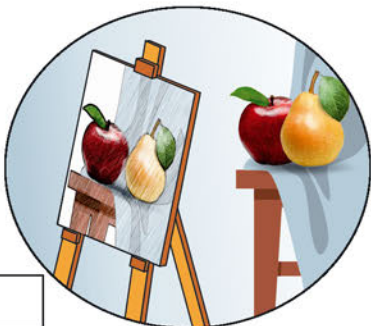

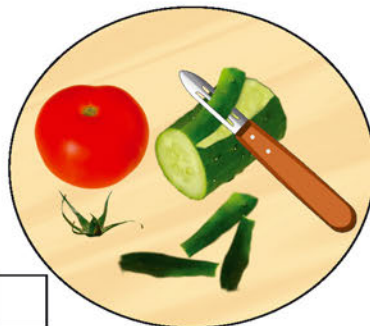

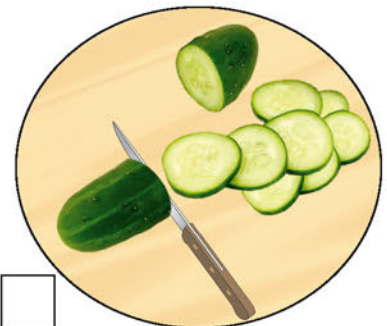



Огради частите на растенията, които се използват за храна от хората?

Отбележи със знак „✓“ дейностите за приготвяне на салата.

Нови понятия
• хранителен продукт

Чинийка от хартия

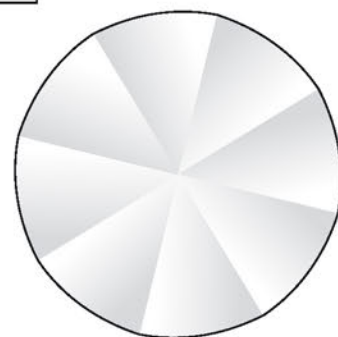
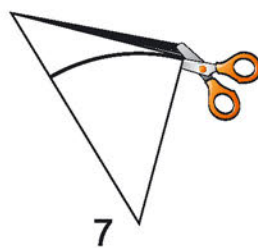
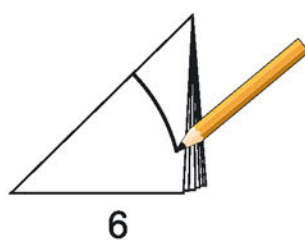
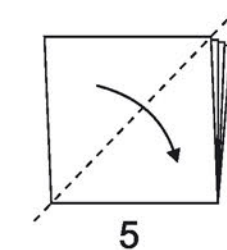
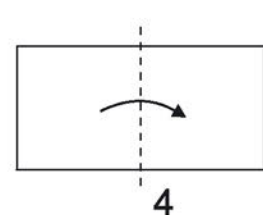
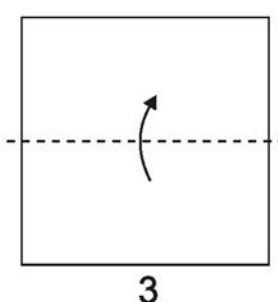
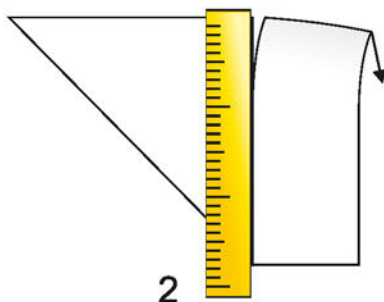
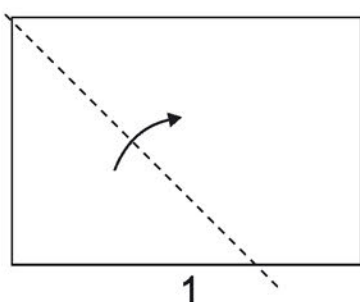
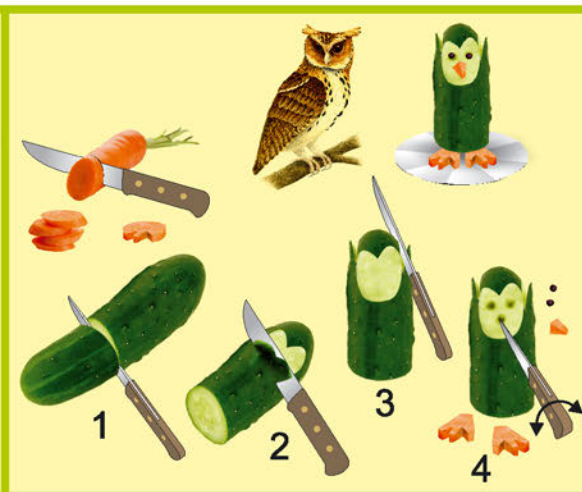
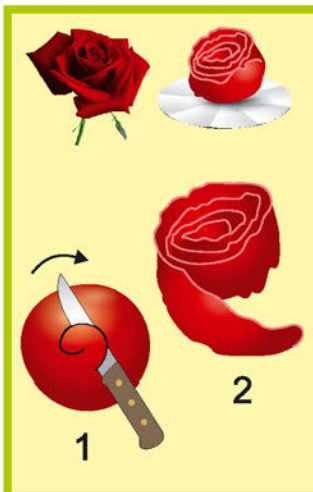
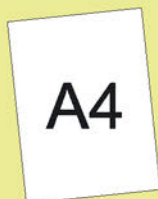

Начини за изработване на забавни фигури от плодове и зеленчуци за украса на салата













Направи чинийка от хартия.



Направете изложба с изработените фигури. Представете своите изделия и посочете предимствата им.

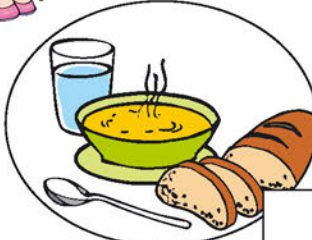





 Отбележи със знак „✓“ най-важните твои потребности.

 Отбележи със знак „+“ нещата, от които се нуждаеш и без които не можеш, а със знак „-“ нещата, които желаеш, но без които можеш.

Дърво на желанията



АЛБУМ

Пр. 3
Пр. 9

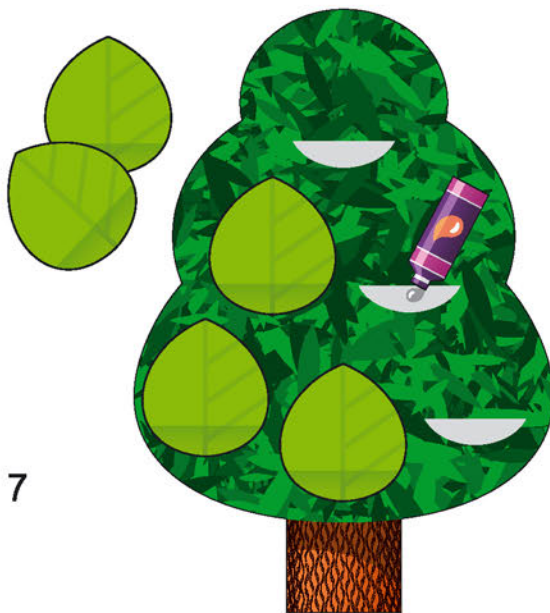
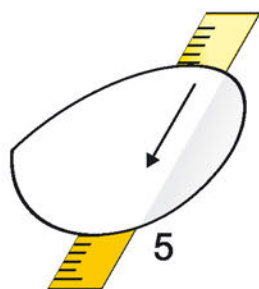
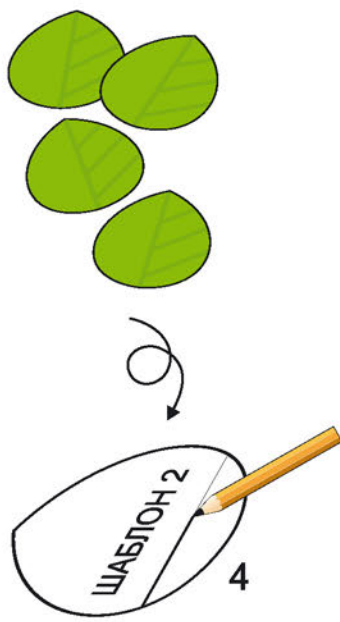
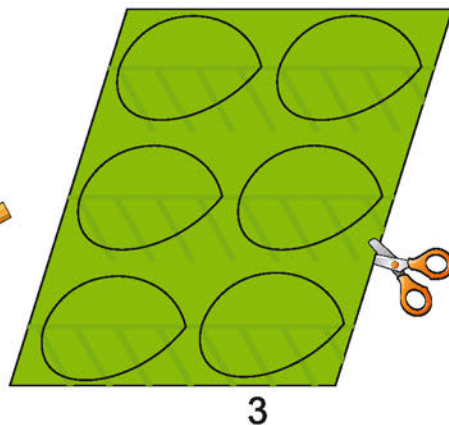
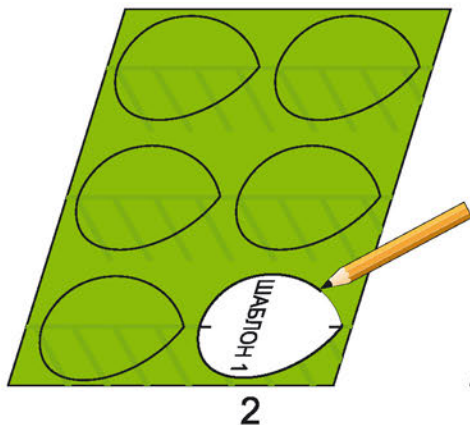
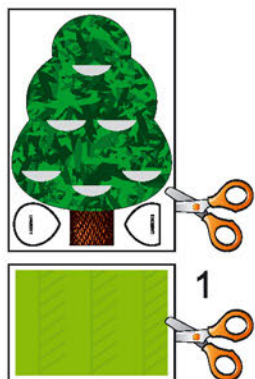
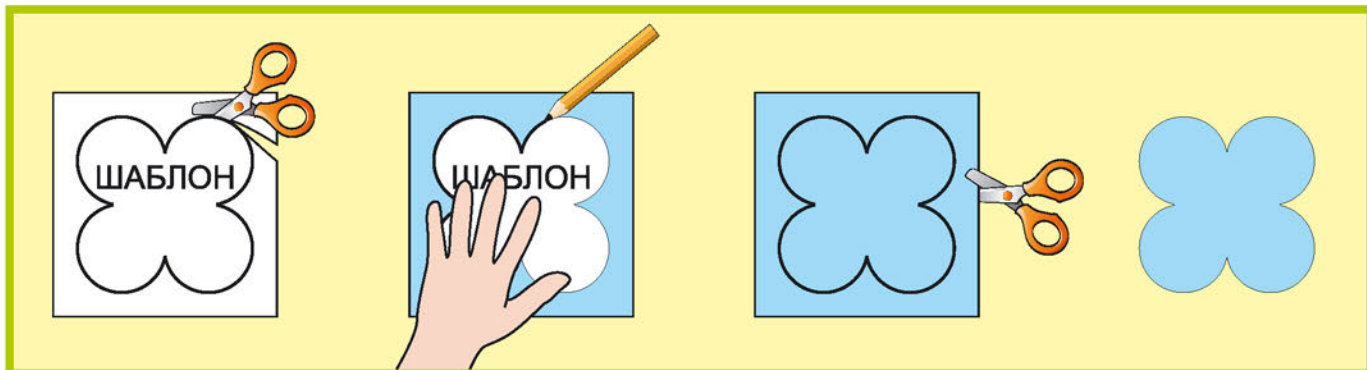
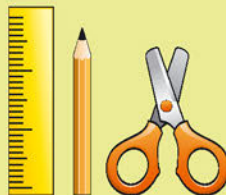

 Начин за очертаване с шаблон

 Напиши или нарисуй своите желания върху листчетата от приложение № 4 и направи Дърво на желанията.

Нови понятия
• шаблон

ЕЛЕКТРИЧЕСТВОТО У ДОМА

Електрическа змия

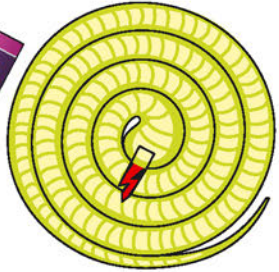
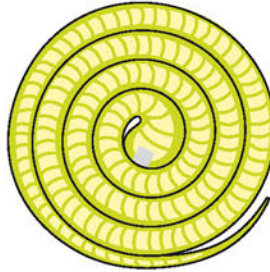
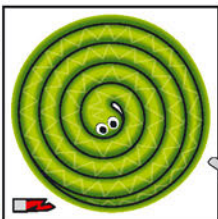

1



2



3



Свържи уредите със съответния източник на електричество.



Направи електрическа змия от хартия.



Демонстрирай играта с електрическата змия.

ДА ПЕСТИМ ЕНЕРГИЯТА

Табелки с правила

10

АЛБУМ
Пр. 10

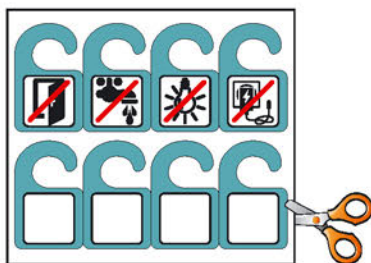
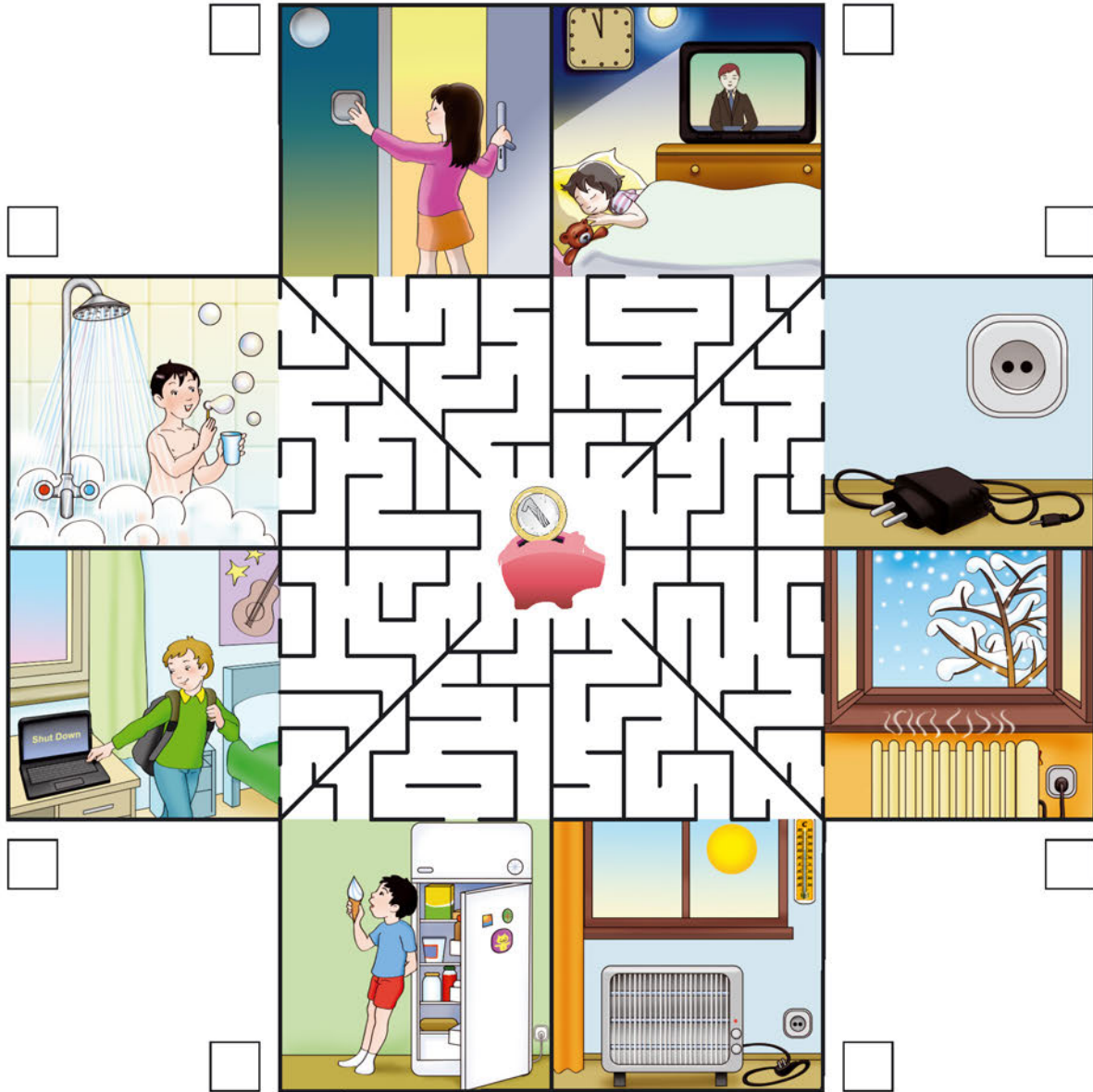

- Как да пестим енергия у дома? Отбележи със знак „+“ картинките, които показват пестене на енергия, а със знак „-“ картинките, които показват разхищение на енергия. Проследи лабиринта, за да провериш отговорите си.
- Направи табелки с правила за пестене на енергия. Закачи табелките на подходящите места у дома.
- Измисли и нарисуйвай други правила за пестене на енергия. Представи словесно идеите си.

15



















За какво получаваш пари? Отбележи със знак „✓“.

За какво харчиш парите си? Би ли постъпил като детето от комикса?

Нови понятия
• личен бюджет

Вълшебно портмоне

АЛБУМ

Пр. 5
Пр. 15

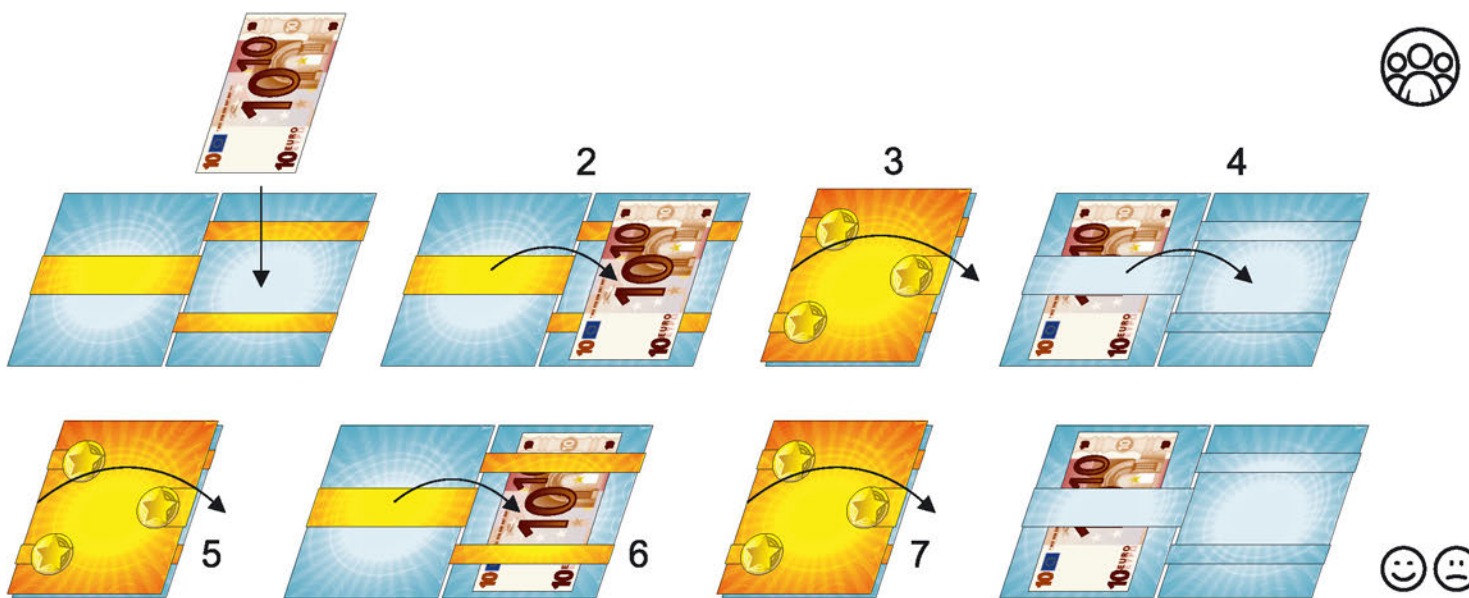
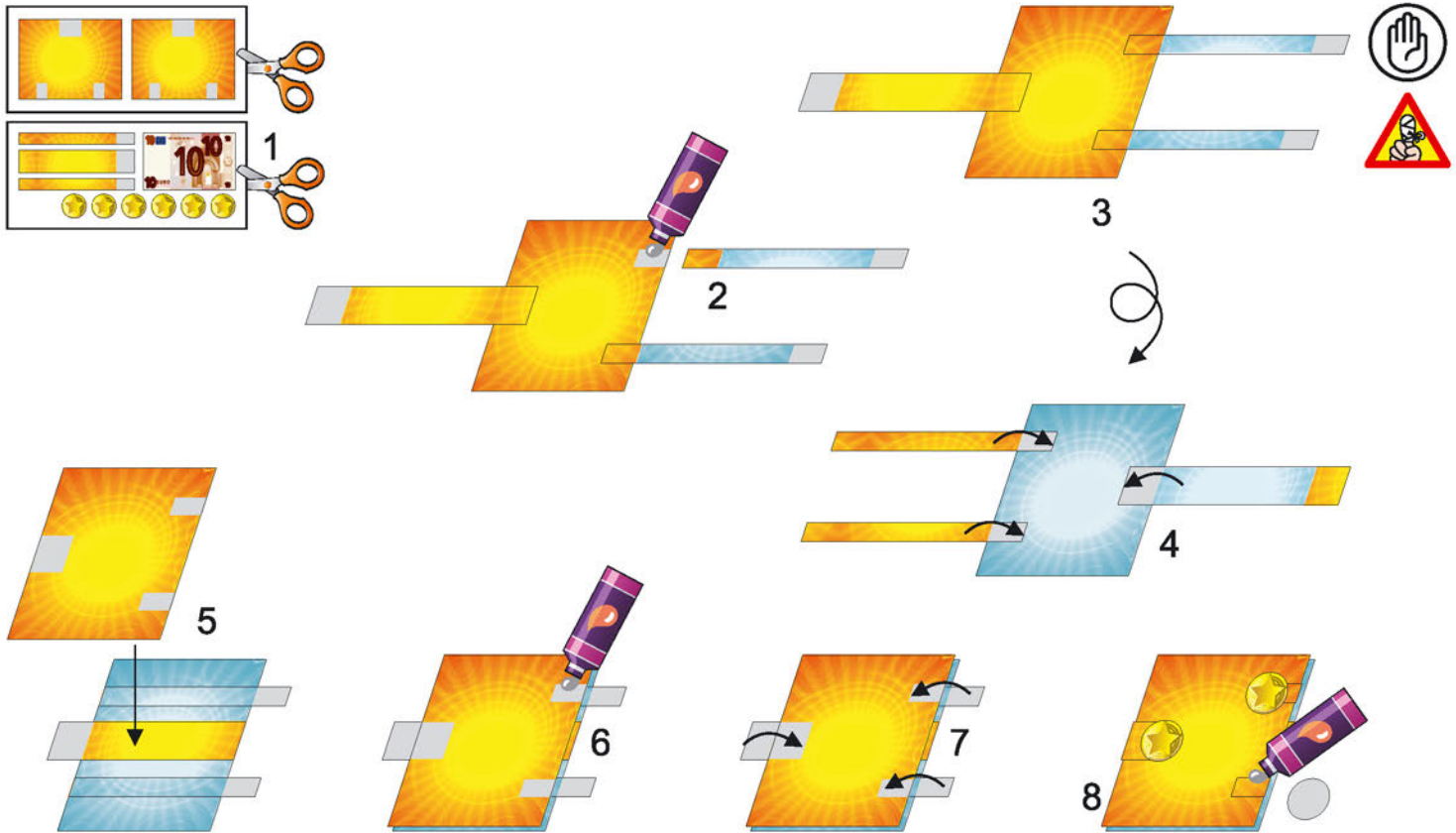

Направи вълшебно портмоне от хартия.

Демонстрирай магията на вълшебното портмоне. Представи словесно изделието.



АЛБУМ
Пр. 12

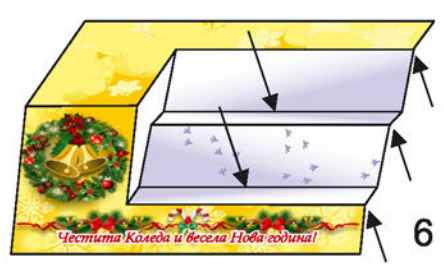
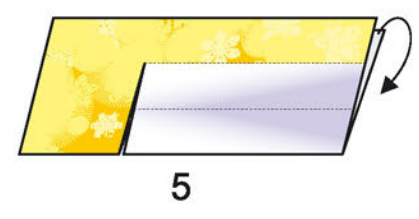
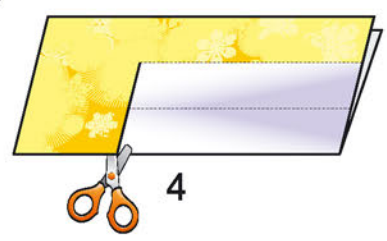
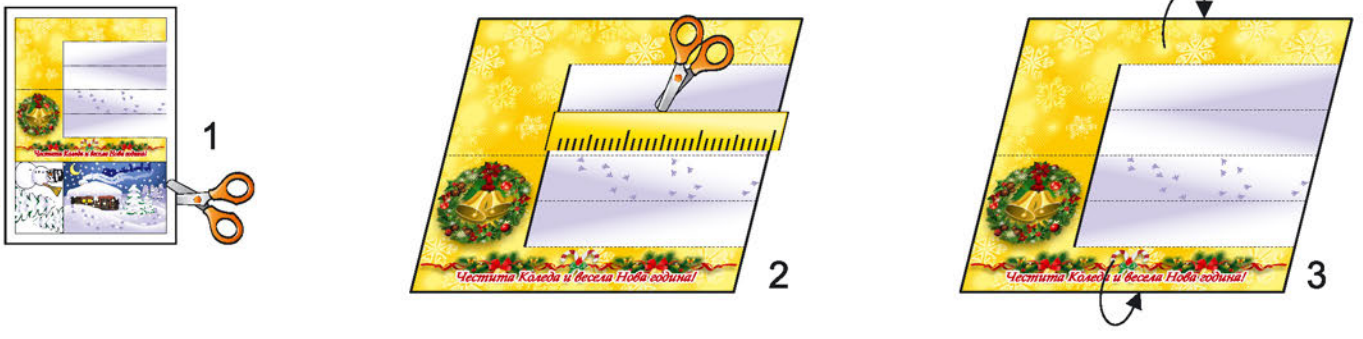
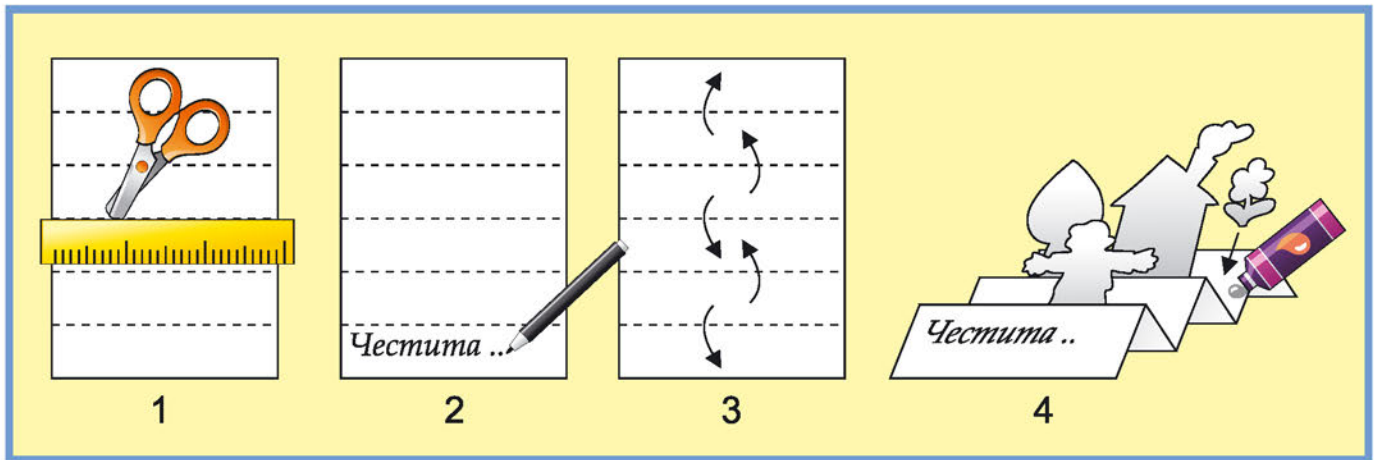
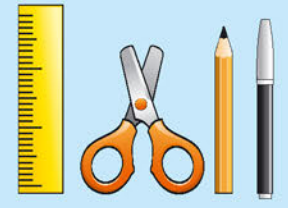

Начин за изработване на стъпаловидна картичка

Направи картичка за Коледа и Нова година.

МНОГОСЛОЙНО ИЗРЯЗВАНЕ

Снежинки



13

АЛБУМ
Пр. 26

A4

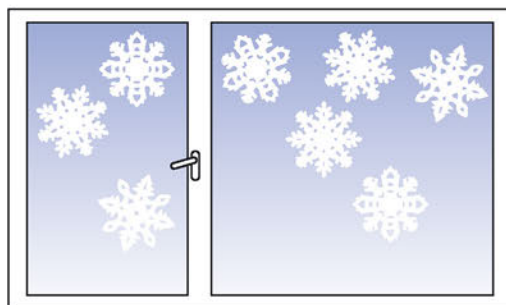
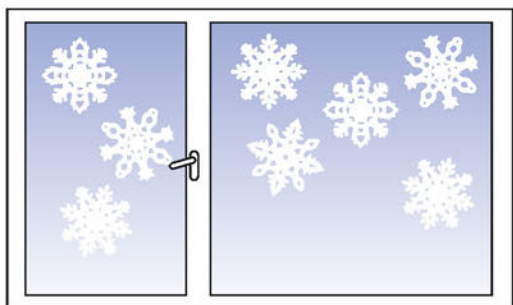
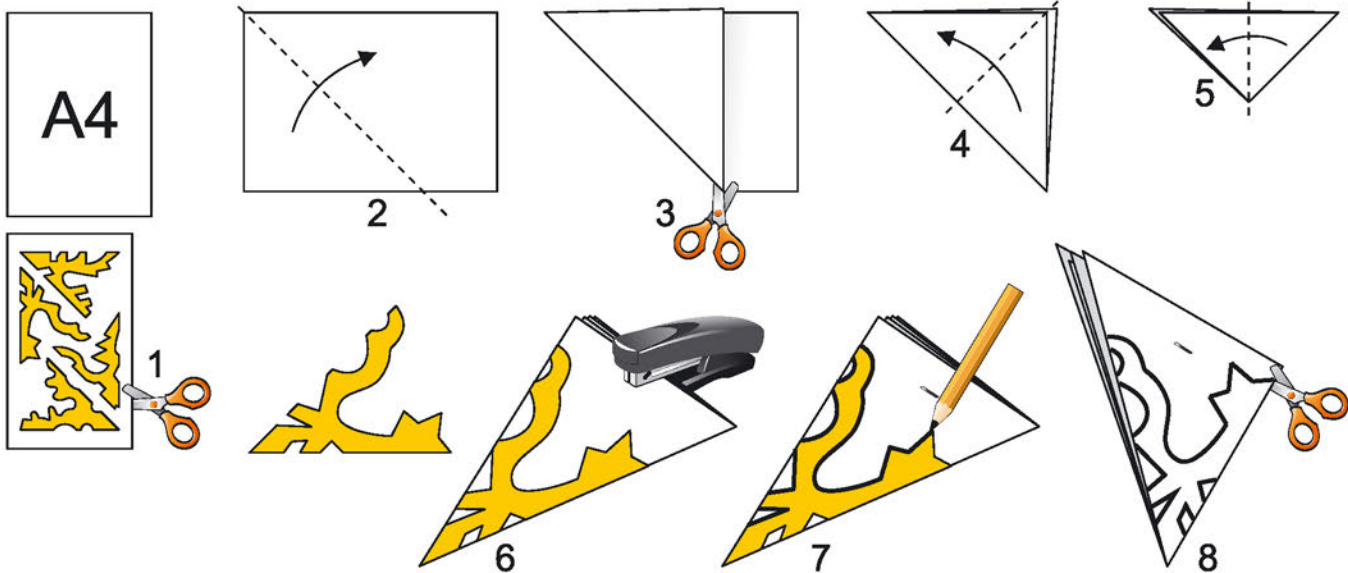
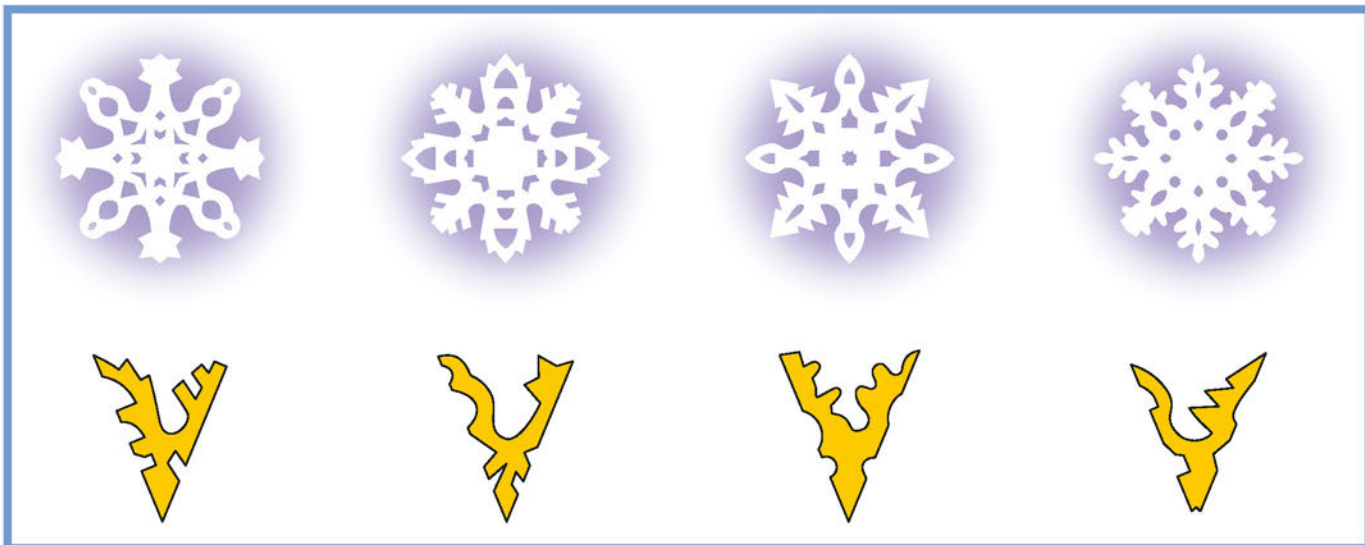

 Свържи показаните хартиени снежинки със съответните шаблони. Какви фигури откриваш в снежинките?

 Избери шаблон и направи снежинка от хартия.

 Украсете прозорците на класната стая със снежинки.

19



КНИЖАРНИЦА

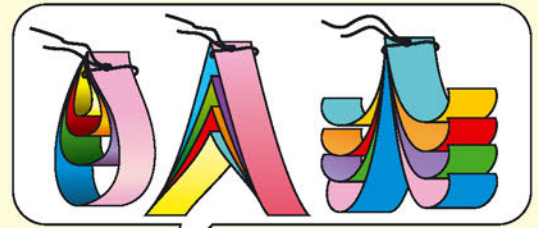
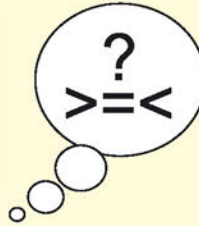



Прочуи какви украшения за Коледа и Нова година продават в книжарницата и колко струват.

Обсъдете различни варианти за закупуване или изработване на празнична украса. Изберете вариант.

Отбележи какви материали можеш да използваш за изработване на празнична украса.

Нови понятия
• цена

Украса за елхата

АЛБУМ
Пр. 37

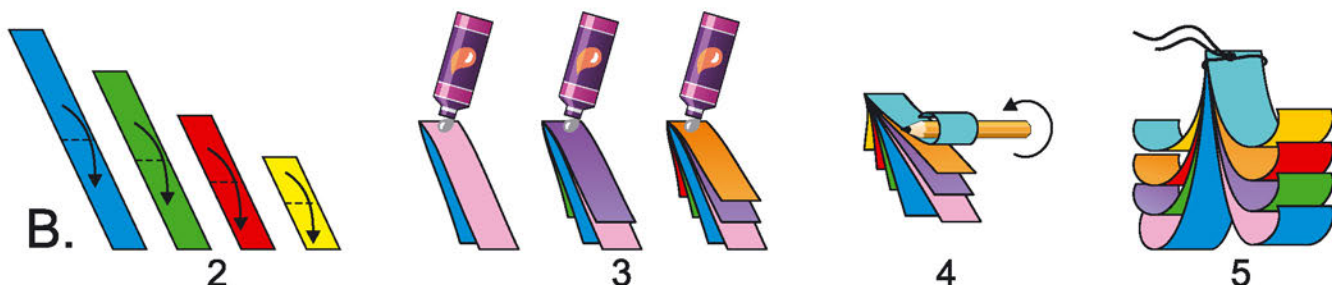
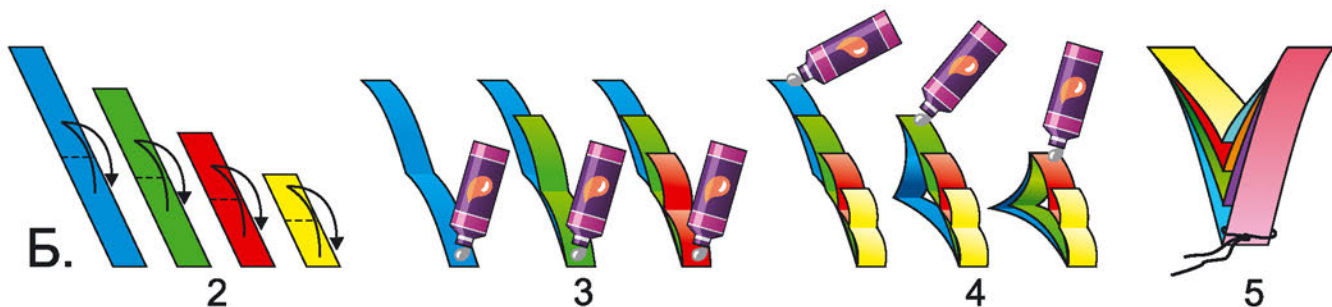
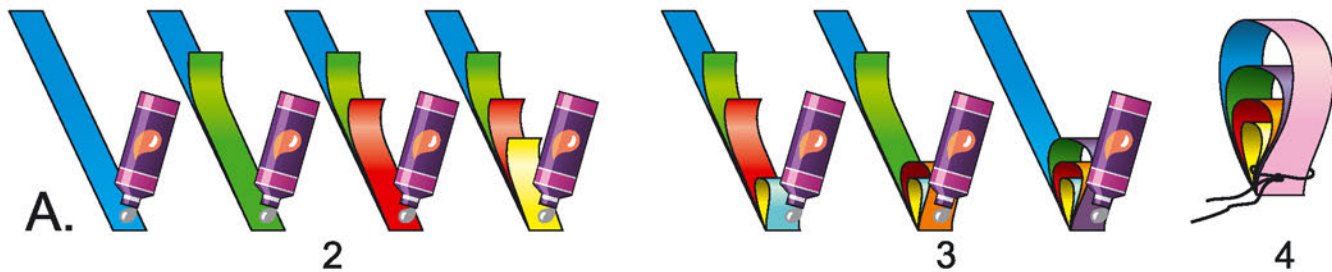
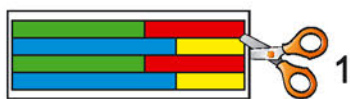
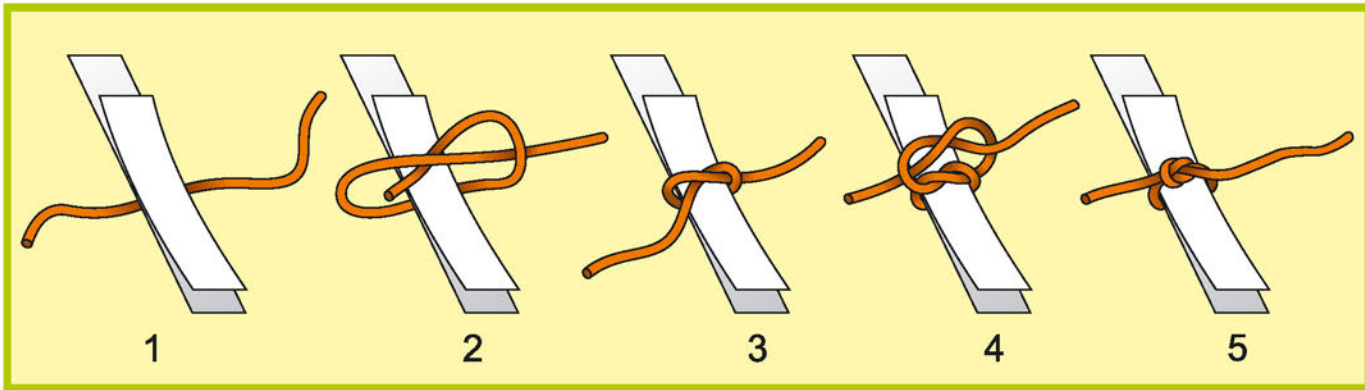

 Начин за връзване с конец „На възел“.

 Направи висящо украшение за елхата по избор.

 Свържи наименованията на грижите, които трябва да полагаш за домашния любимец всеки ден, със съответните картинки.

разхождане		хранене		
				
разресване		лекуване		почистване

 Разгледай техническите рисунки на показаните жилища на животни. По какво се различава техническата рисунка от снимката на едно изделие?

			
-------------------------------------------------------------------------------------	-------------------------------------------------------------------------------------	--------------------------------------------------------------------------------------	---------------------------------------------------------------------------------------

 Избери домашен любимец. Проучи какво е необходимо за неговото отглеждане. Направи техническа рисунка на жилището му.



Необходимо:

Жилище



Куче и коте

МАТЕРИАЛИ И ИНСТРУМЕНТИ

- приложения № 6 и 28
- лепило
- летвички
- ножица
- флумастери



Направи оригами „Куче“ и „Коте“. Оцвети изображенията на животните.

1

2

3

4

5

6

7

8

2

3

4

5

6

7

8

9

Разкажете и драматизирайте приказката за кучето и котката в жилището на човека.





КОЛЕЛАТА В ТЕХНИКАТА И БИТА

Акробат

МАТЕРИАЛИ И ИНСТРУМЕНТИ

- приложение № 17
- ножица
- ос



Разкажи историята на колелото по картинките.

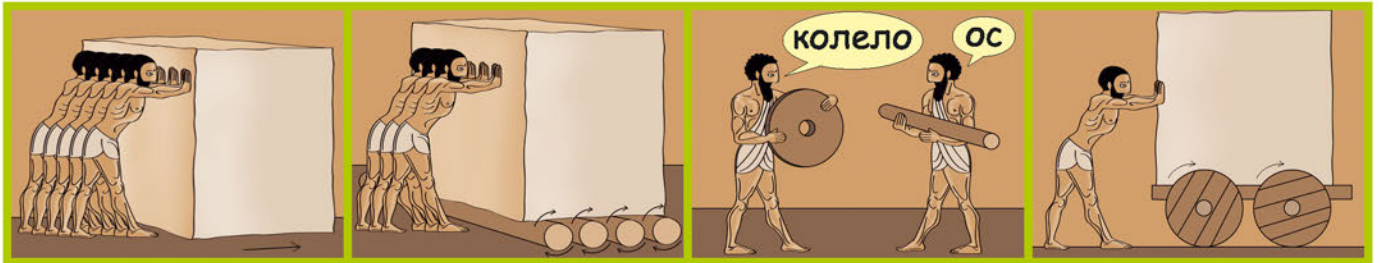

Отбележи със знак „✓“ вярното приложение на колелата в техниката и бита.

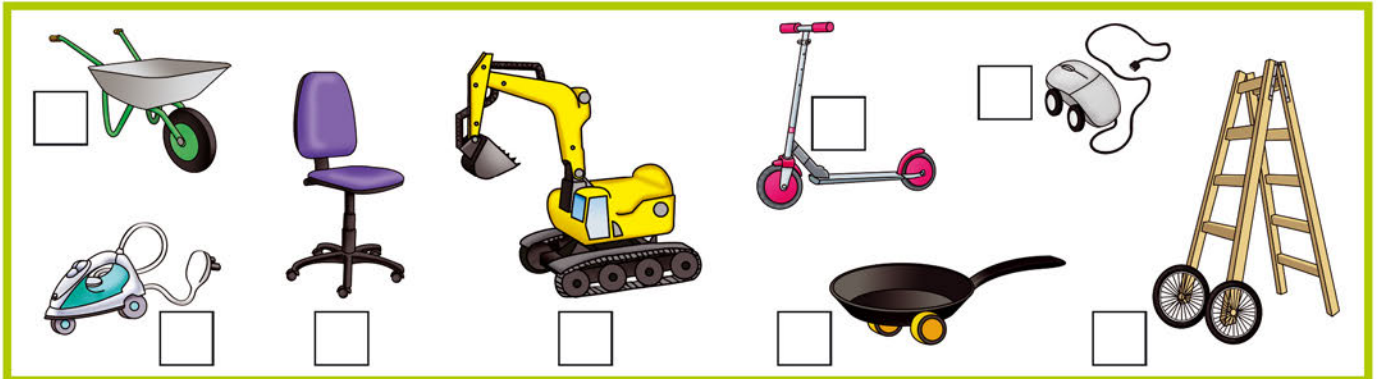

Направи модел на акробат върху велосипед с едно колело.

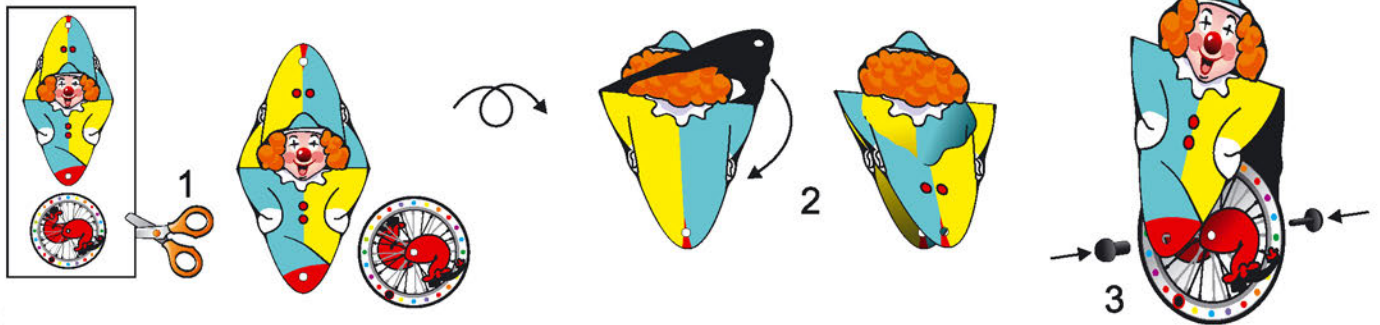

Колко завъртания ще направи колелото за една обиколка на манежа? Преброй и ги отбележи.



Брой завъртания:

- Нови понятия
- модел
 - подвижно съединяване

СВЕТЪТ НА МАШИНИТЕ

Спортна кола

17

МАТЕРИАЛИ И ИНСТРУМЕНТИ

- приложение № 20
- ножица
- бси
- лепило



От какво са съставени машините?



Направи модел на спортна кола.

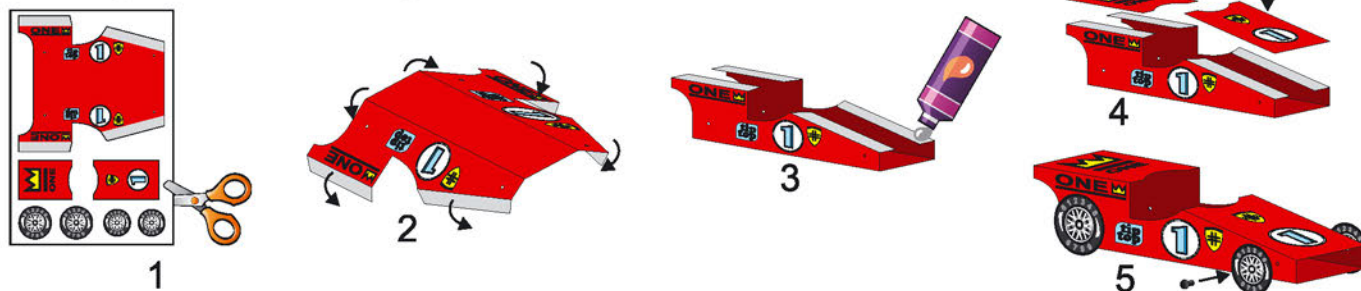

Кой модел ще измине по-голямо разстояние?



Направете състезание с изработените модели.

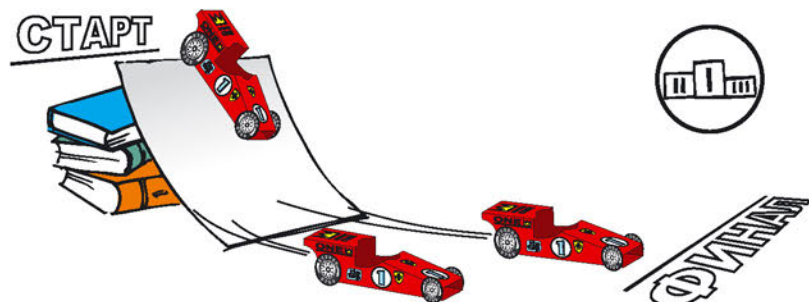

№	Състезател	Разстояние
1.		
2.		
3.		



- Нови понятия
- част
 - механизъм
 - машина

25



РАБОТА С ПРЕЖДА

Мартеници

МАТЕРИАЛИ И ИНСТРУМЕНТИ

- приложение № 22
- бяла и червена прежда
- ножица



Кога и защо връзваме мартеници от бял и червен конец? До кога се носи мартеницата?



Начин за изработване на панделка.

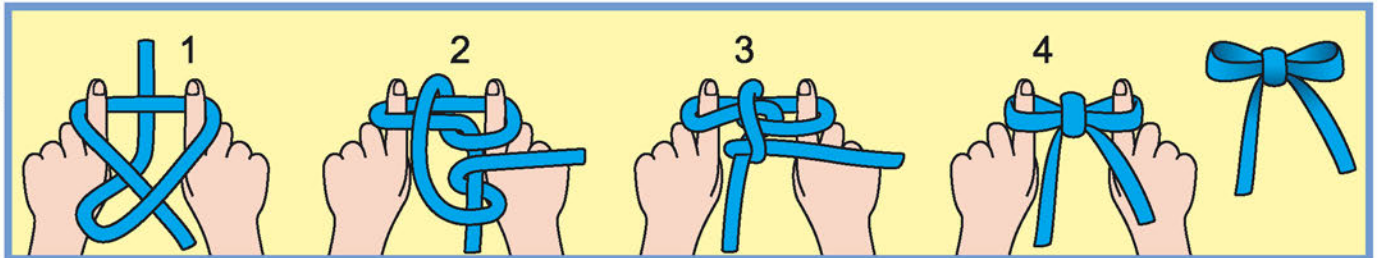

Направи мартеници пискюли.

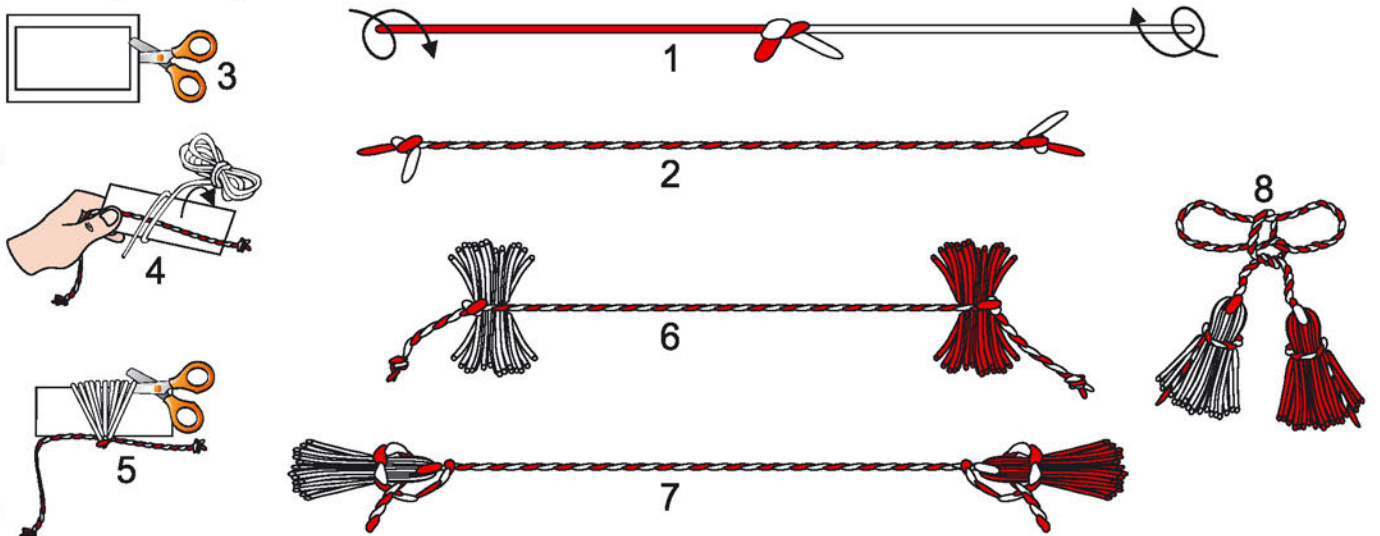

Направете благотворителна изложба базар на мартеници под наслов „Деца помагат на деца“.

ХАРТИЕНИ РОЛКИ

Герданче

19

МАТЕРИАЛИ И ИНСТРУМЕНТИ

- приложение № 7
- сламка, шнурче
- клечка за зъби
- лепило
- ножица
- флумастер



Начини за изработване на ролки от хартия

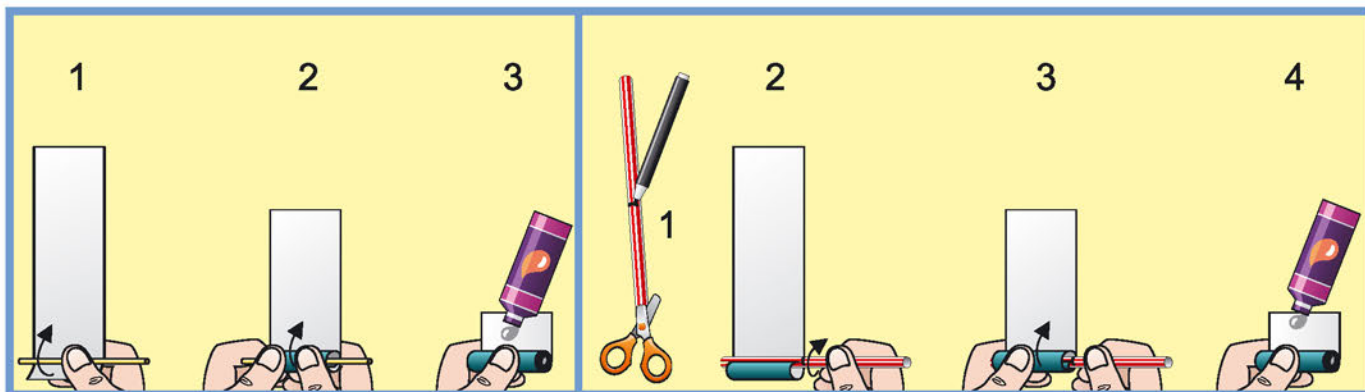

Направи герданче от хартиени ролки.

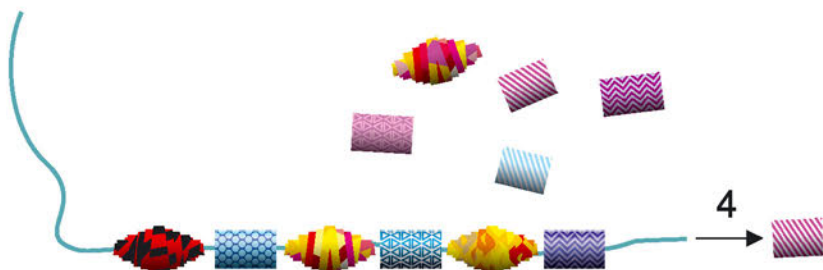
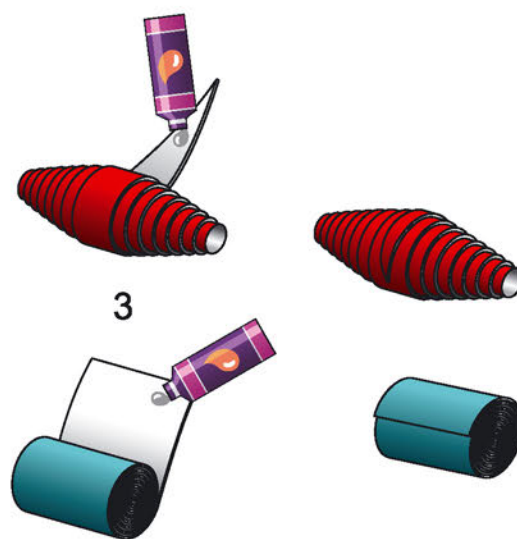
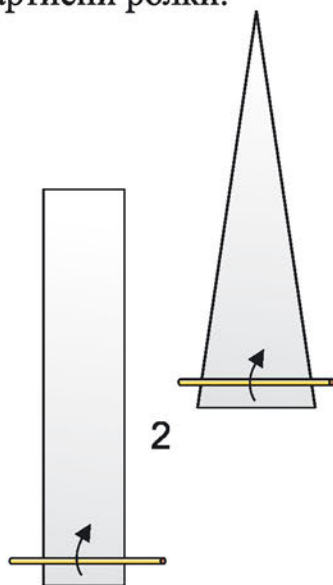
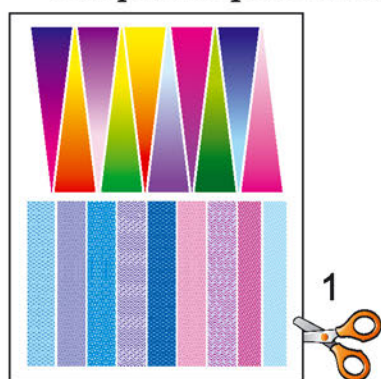



ОПАКОВКА ЗА ПОДАРЪК

Торбичка и етикет

МАТЕРИАЛИ И ИНСТРУМЕНТИ

- приложения № 18 и 33
- шнураче
- лепило
- ножица
- перфоратор



Начин за връзване „На панделка“

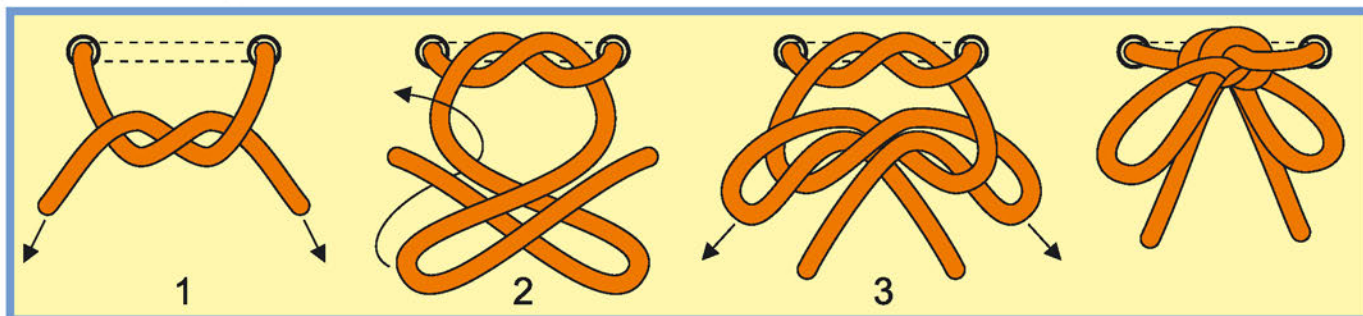

Направи торбичка с етикет за подарък.

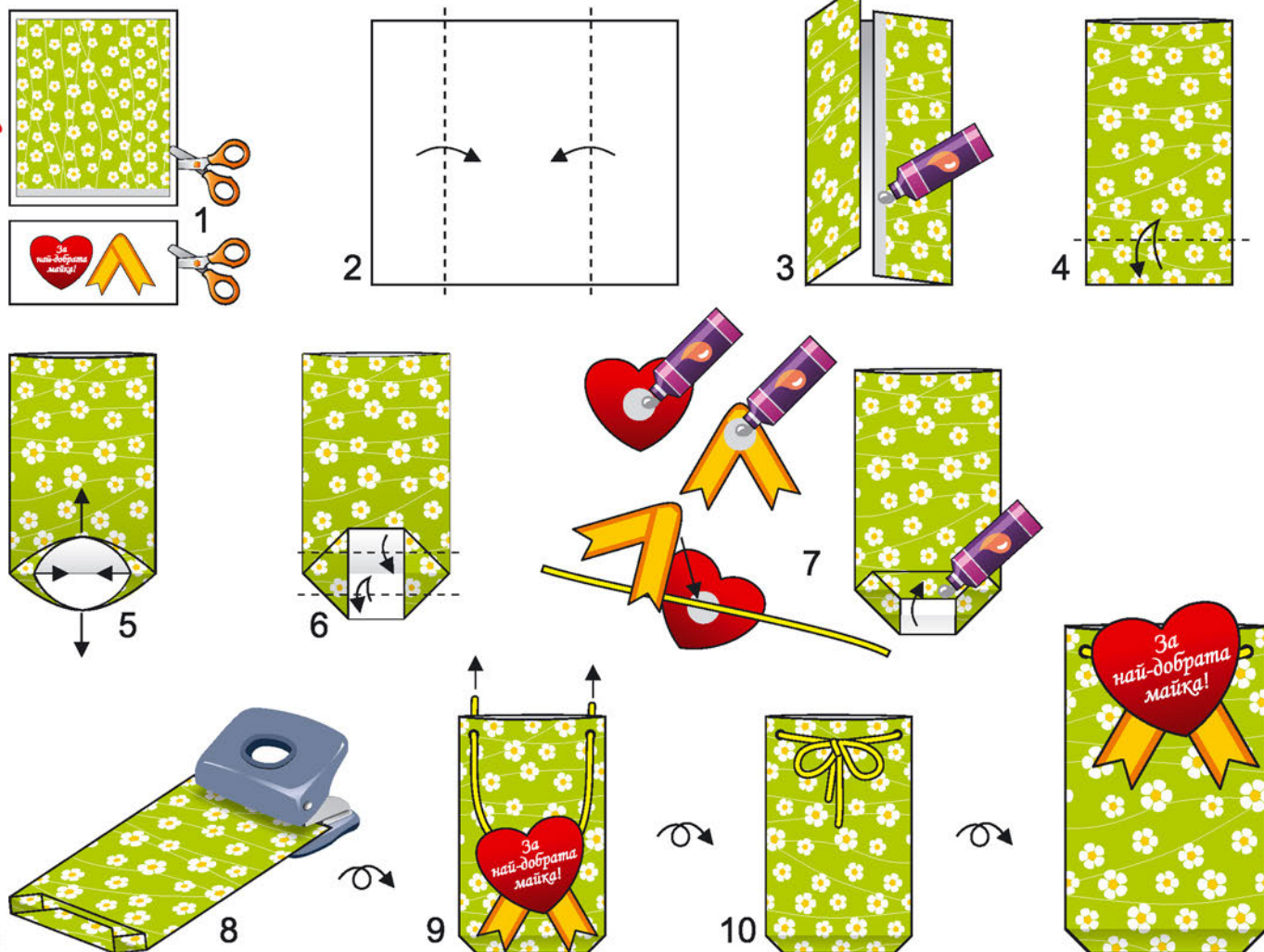

ПРОЛЕТНА УКРАСА Цвета и пеперуди

21

МАТЕРИАЛИ И ИНСТРУМЕНТИ

- приложения № 16 и 35
- ножница
- линейка
- лепило



Направи пролетна картичка и венец или гирлянд по избор.

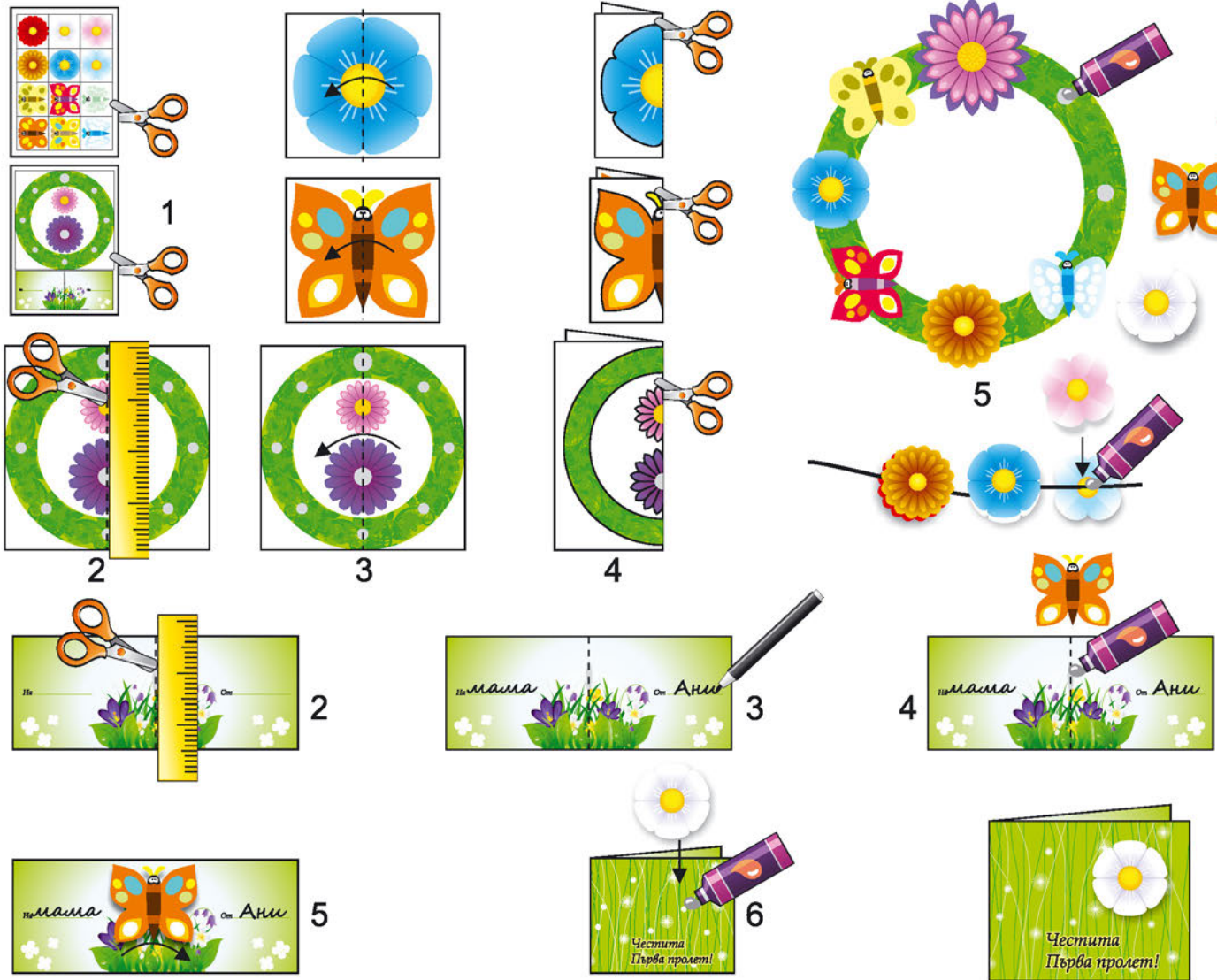

Украсете класната стая с венци и гирлянди от цвета и пеперуди.

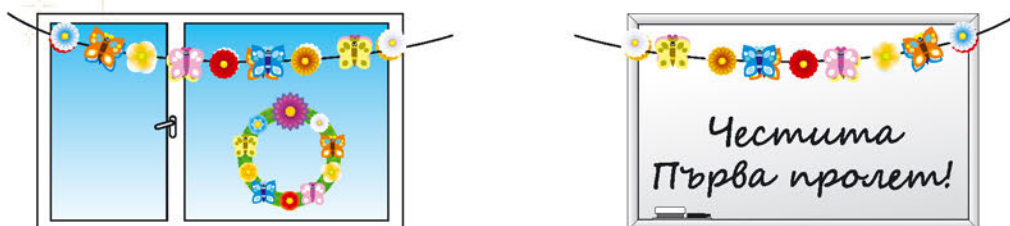

29



Какви грижи се полагат за стайните растения?



Познаваш ли тези растения? Какво показват символите под всяко от тях? Отбележи със знак „✓“ растенията, които могат да се отглеждат в стаята.









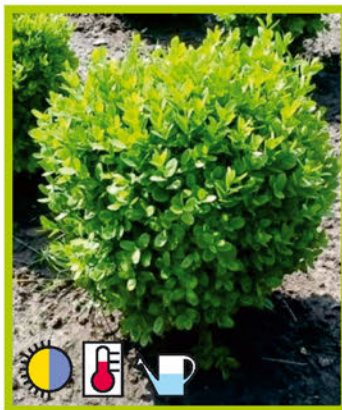





Проект „Осинови растение“

МАТЕРИАЛИ И ИНСТРУМЕНТИ

- приложение № 29
- шишче
- лепило
- ножица
- флумастери



1. Избери си растение у дома, в класната стая или в коридора на училището.



2. Проучи информация от различни източници за условията и грижите, необходими за отглеждане на твоето растение. Отбележи ги в картата със знак „✓“.



КАРТА



Растение: _____

Светлина:

Топлина:

Вода:



3. Направи етикет на растението.

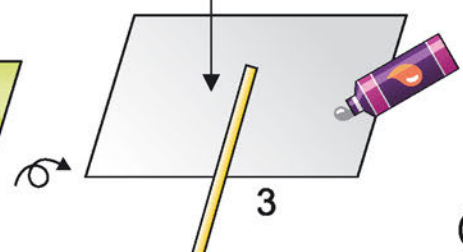
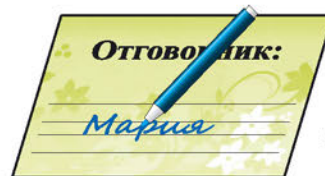
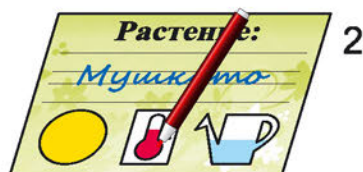
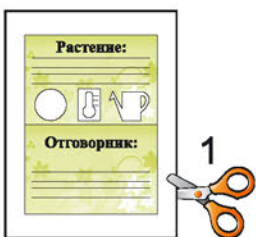



ЗА ПРАЗНИКА НА БУКВИТЕ

Покана

МАТЕРИАЛИ И ИНСТРУМЕНТИ

- приложение № 23
- лист рисувателна хартия
- кламер
- лепило
- ножица
- молив
- флумастер
- линейка



Начин за съединяване на елементи от хартия чрез преплитане

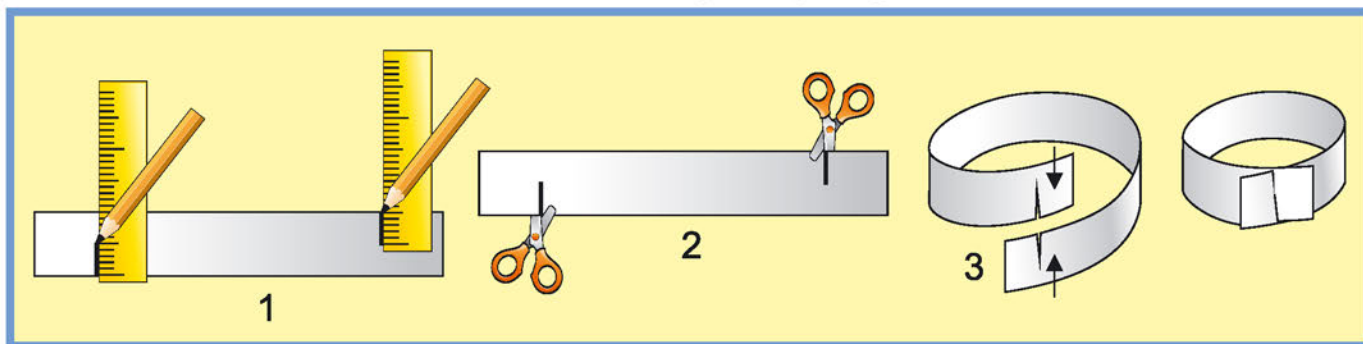

Направи покана и корона с твоята буква.

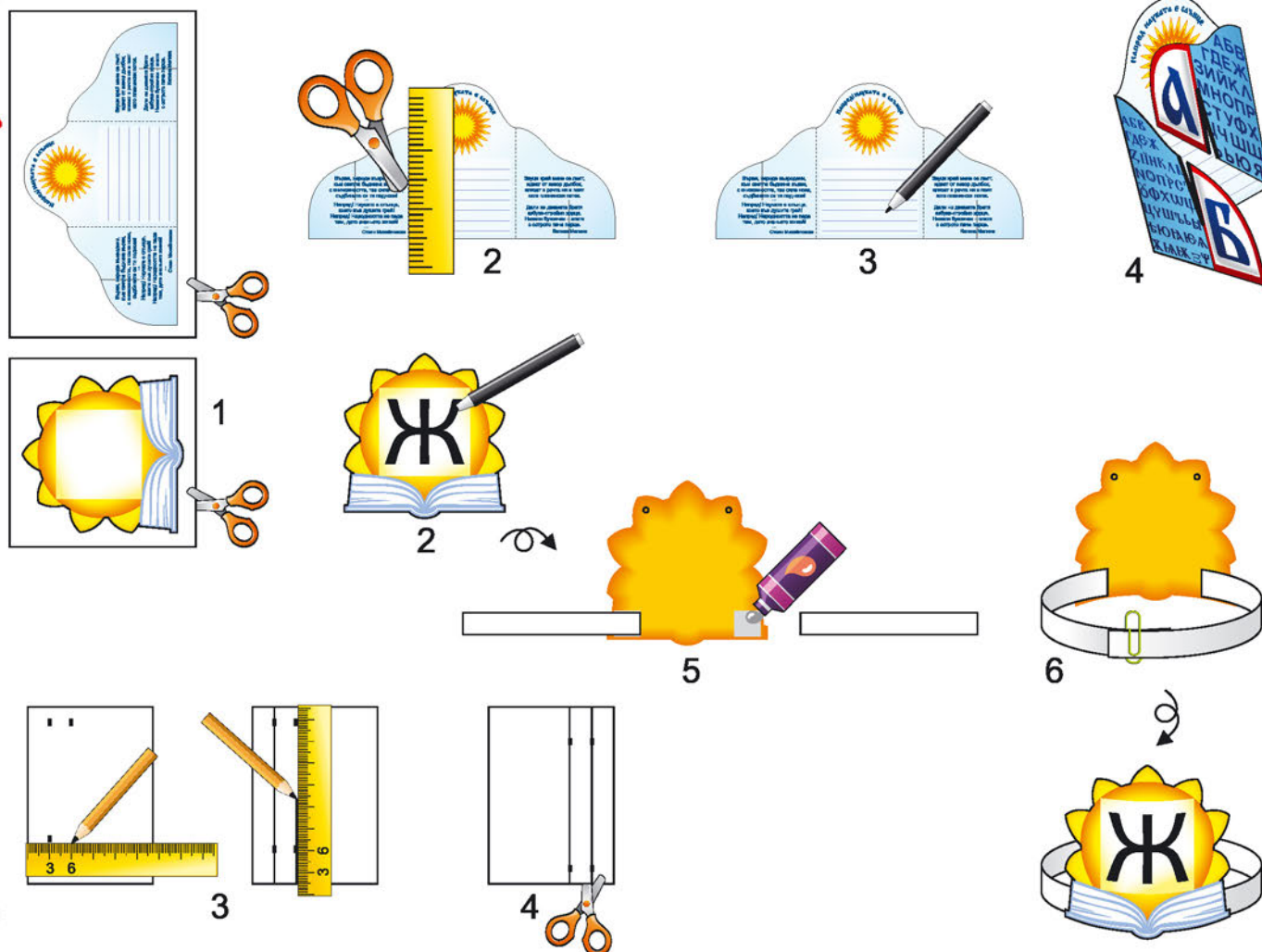

МАТЕРИАЛИ И ИНСТРУМЕНТИ

• приложение № 11

• ножица



Защо се боядисват и подаряват великденски яйца?

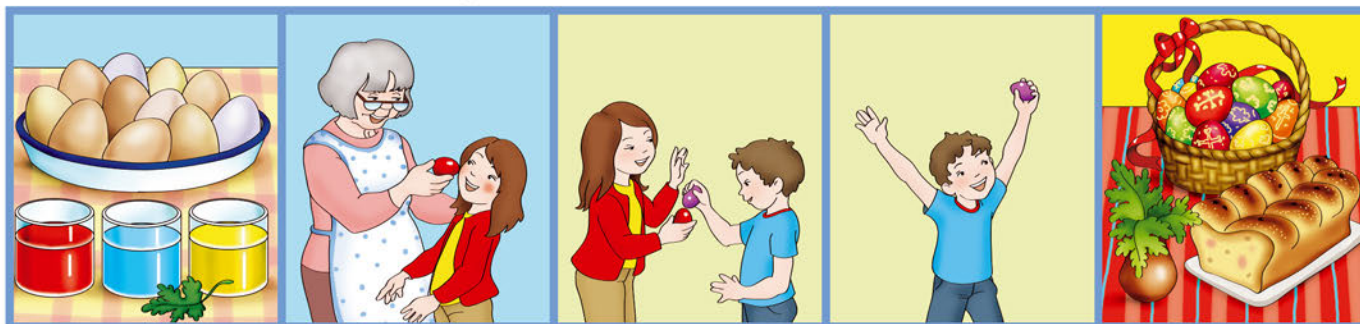

Начини за боядисване и украсяване на великденски яйца

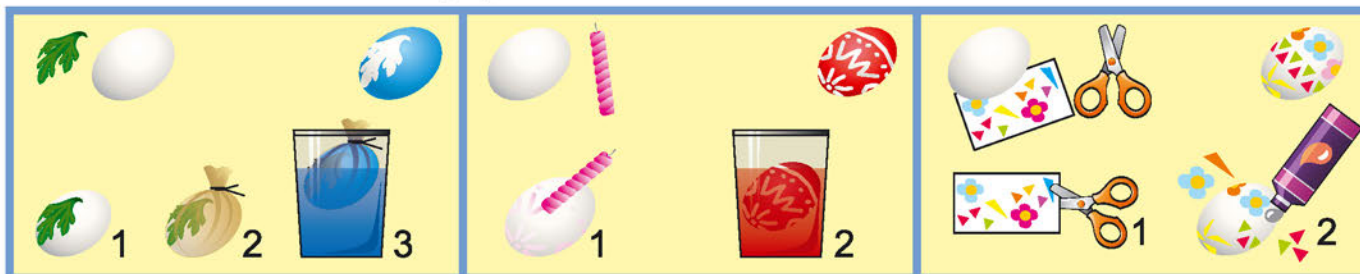

Направи кошничка за великденско яйце.

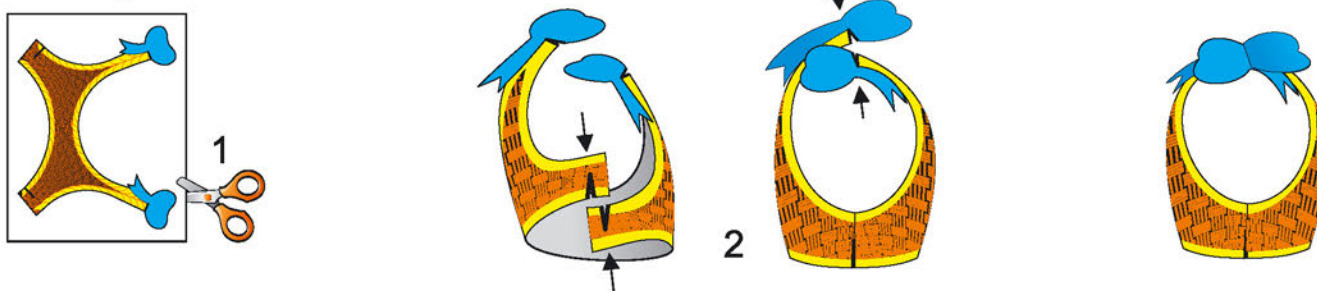

Кой се нуждае от вашата щедрост и милосърдие? Организирайте благотворителна акция.





ТЕХНИКА И ТЕХНОЛОГИИ

Лунна станция

МАТЕРИАЛИ И ИНСТРУМЕНТИ

- приложение № 30
- лепило
- ножица
- молив
- линийка

? Разгледай комикса, прочети и преразкажи разговора между двете деца. Обясни казаното от тях.

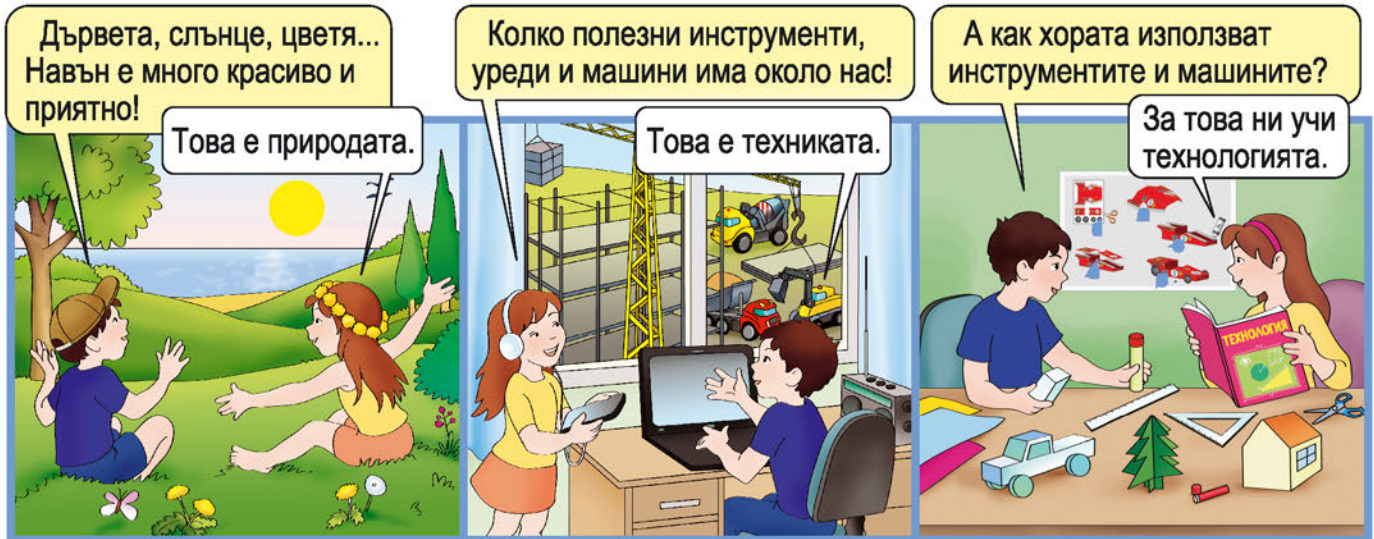

👉 Направи макет трирама „Лунна станция“.

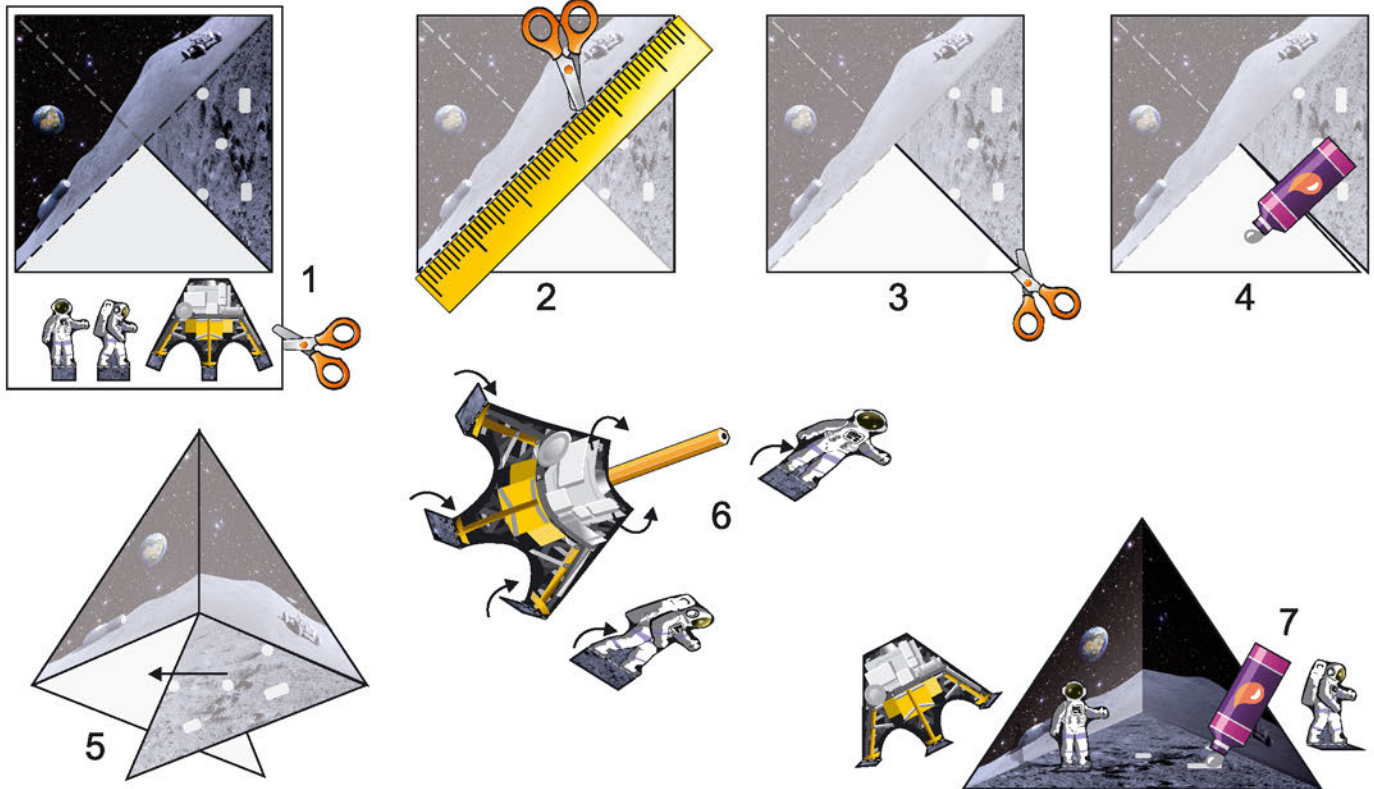

ПРОФЕСИИ Моден дизайнер

МАТЕРИАЛИ И ИНСТРУМЕНТИ

• приложение № 31

• ножица



26

Кои са професиите на тези хора? Какви машини, апарати, инструменти и облекла използват?



Събери информация за професията моден дизайнер. Прочуи и напиши какво прави модният дизайнер.



Направи дрехи за манекените в три различни стила – спортен, карнавален и официален. Проектирай и изработи свои модели.

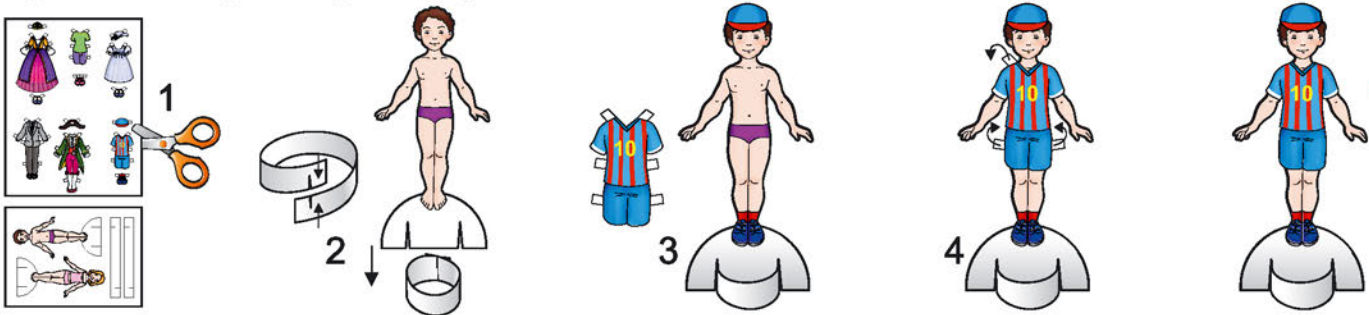

Направете модно ревю за демонстрация на дрехите.



спортен стил



карнавален стил



официален стил



35



ЗА ДЕНЯ НА ЗЕМЯТА

Групов проект „Омагьосаната гора“

МАТЕРИАЛИ И ИНСТРУМЕНТИ

- приложения № 34 и 36
- хартиени ролки
- лепило
- ножица
- МОЛИВ
- ЛИНИЯ



Как човешката дейност променя околната среда?



Направете макет „Омагьосаната гора“ от отпадъчни хартиени ролки.

1. Разделете се на групи по няколко деца.
2. Направете план и разпределете работата помежду си – всеки избира животно или растение, което да изработи.
3. Изработете макета, като предварително определите последователността на операциите и местата за залепване на изрязаните елементи.

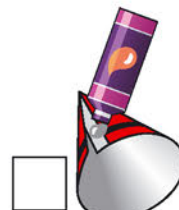
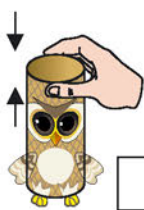
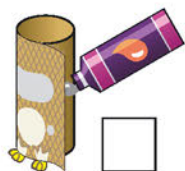
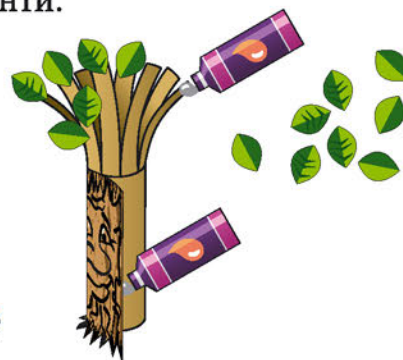
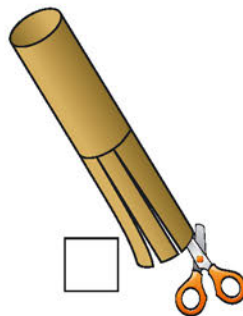
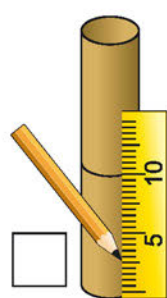
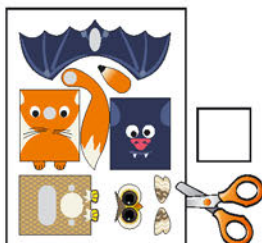

4. Презентирайте готовия макет пред останалите ученици от класа и оценете качествата му.

ИГРАЧКИТЕ НА ДЕЦАТА

Джетмен

28

МАТЕРИАЛИ И ИНСТРУМЕНТИ

- приложения № 24 и 38
- сламка, конец
- лепило, тиксо
- ножица
- линия
- флумастер



Как се задвижват и управляват тези играчки? Свържи съответните картинки.

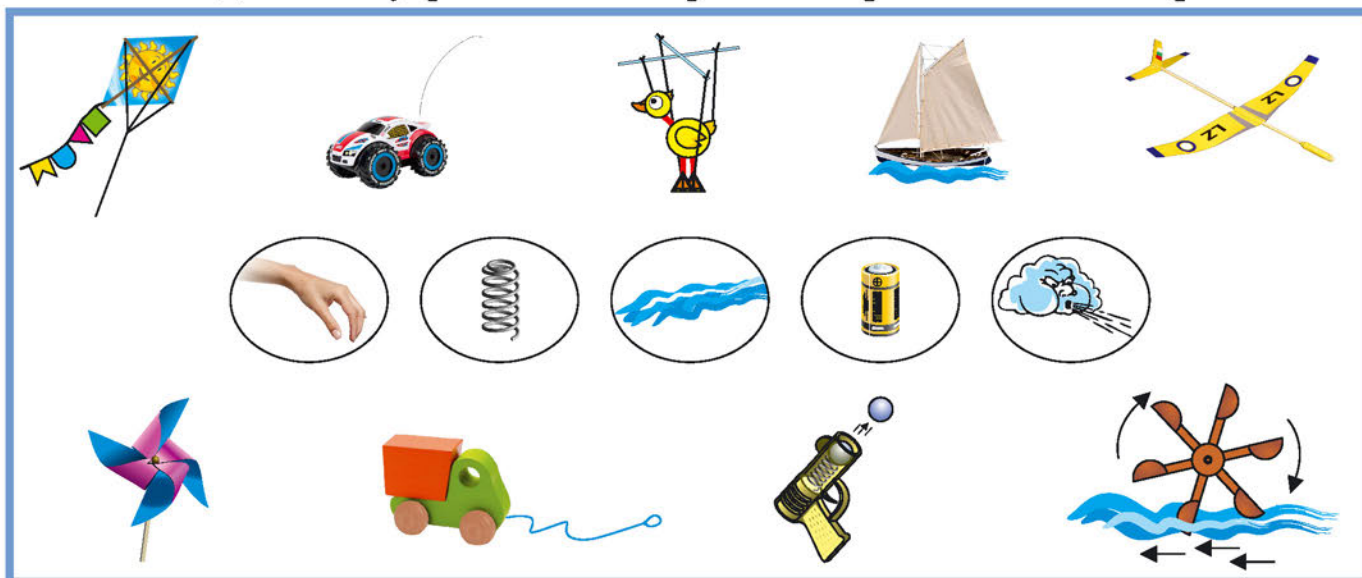

Направи движеща се играчка Джетмен.

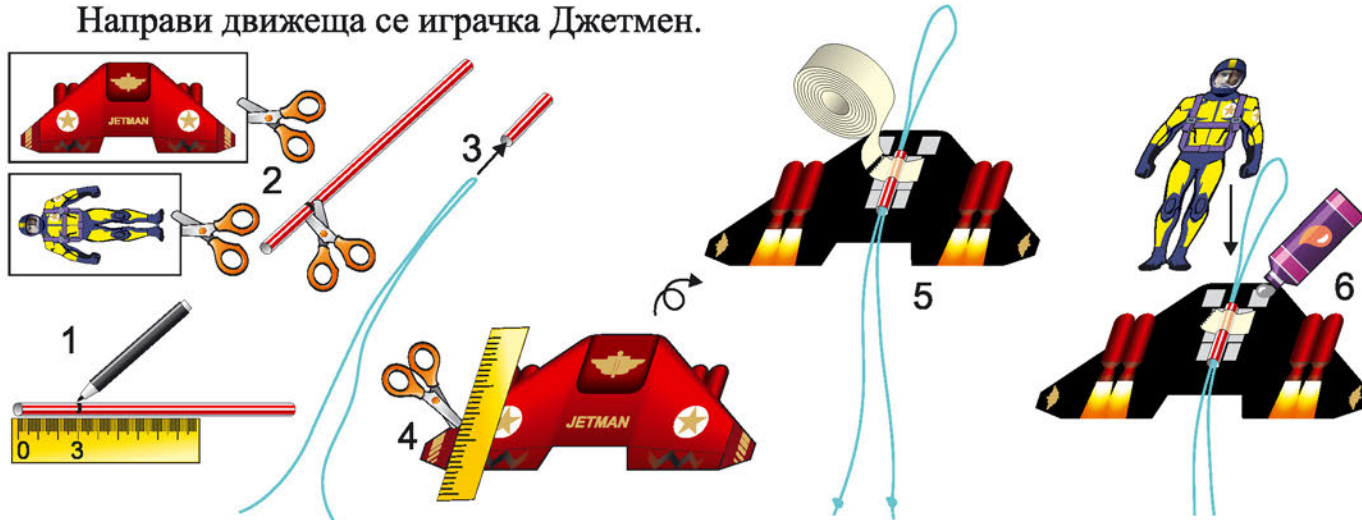

Демонстрирай движението на играчката.

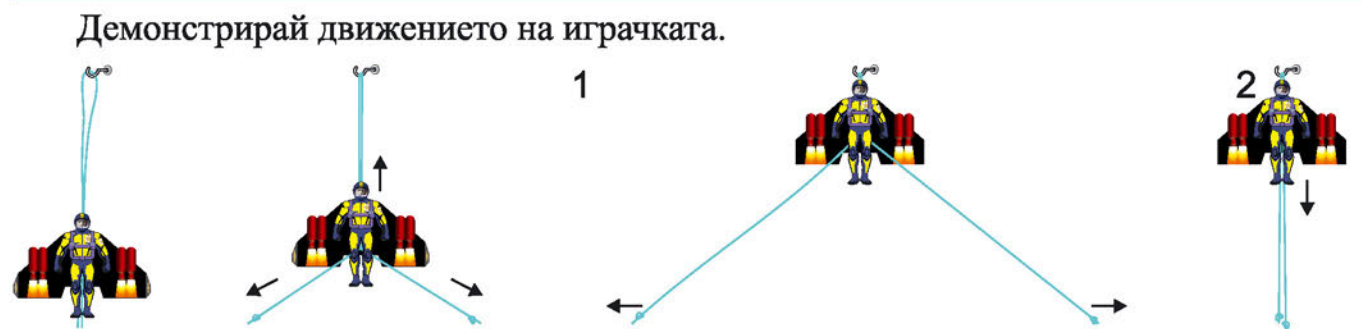

37



В СУПЕРМАРКЕТА

Блокче за бележки

МАТЕРИАЛИ И ИНСТРУМЕНТИ

- приложение № 25
- лист хартия А4
- лепило
- ножица
- линия

? Кога един продукт на човешкия труд става стока? Отбележи със знак „✓“ картинките, които показват стоки.



Подреди със стрелки стоките от количката на съответните рафтове.

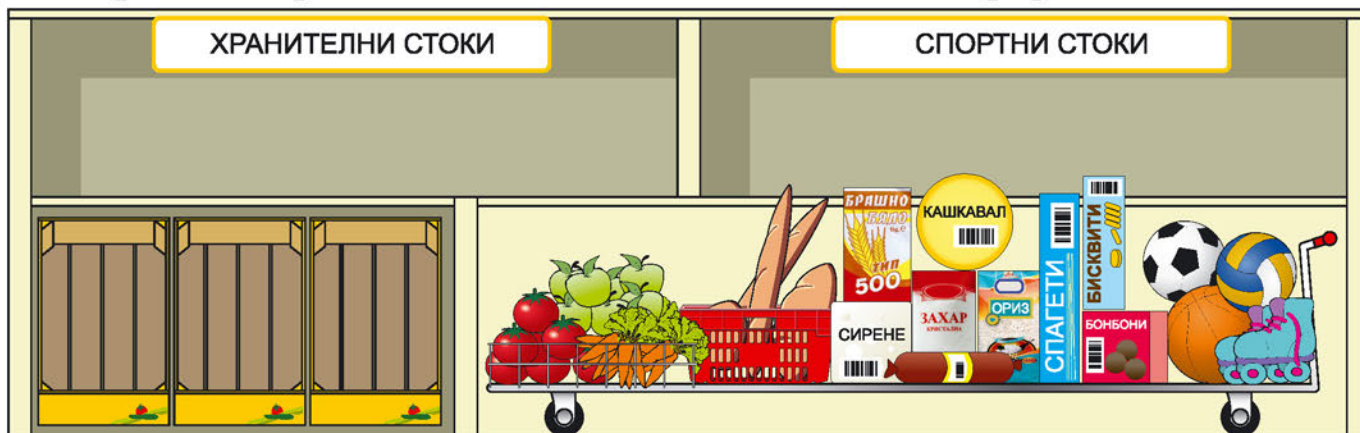

Направи блокче с листчета за списък на покупките.

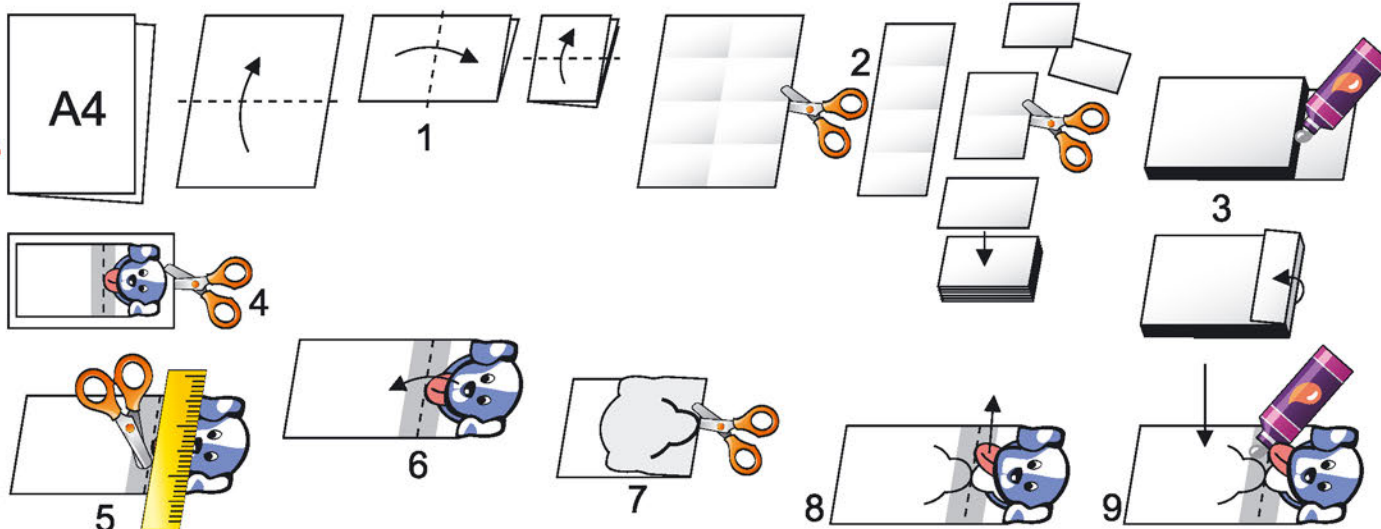

Нови понятия
• стока

СТОКИ И УСЛУГИ

Игра „На пазар“

30

МАТЕРИАЛИ И ИНСТРУМЕНТИ

- приложения № 26 и 32
- ножица
- зарче, пионки



Коя е разликата между стока и услуга?



МОБИЛЕН ТЕЛЕФОН
Цена: 100 лв.



МОБИЛНА МРЕЖА
Цена: 20 ст. за 1 минута



Какво купуваме с пари? Отбележи стоките с буквата „с“, а услугите – с буквата „у“.



Направи игра „На пазар“.



Участват 1–4 играчи.

Правила. Всеки играч избира пионка, изтегля една карта и хвърля зарчето. Първи започва този, който е хвърлил най-много. Ако пионката попадне на червено поле, играчът пропуска покупката. Ако пионката попадне на зелено поле, играчът отбелязва съответната покупка на стока или услуга на своята карта. Всяка направена покупка носи една точка. Печели този играч, който събере най-много точки.



Нови понятия
• услуга

39



Познаваш ли тези знаци за визуална комуникация с пръсти?

Да! Одобрявам!		Не! Не одобрявам!		Внимание!		Съгласен съм!	
ОК! Всичко е наред!		Обичам те!		Мир! Победа!		Обади ми се!	



Колко различни начина за използване на електронни комуникационни средства знаеш? Отбележи със знак „✓“.

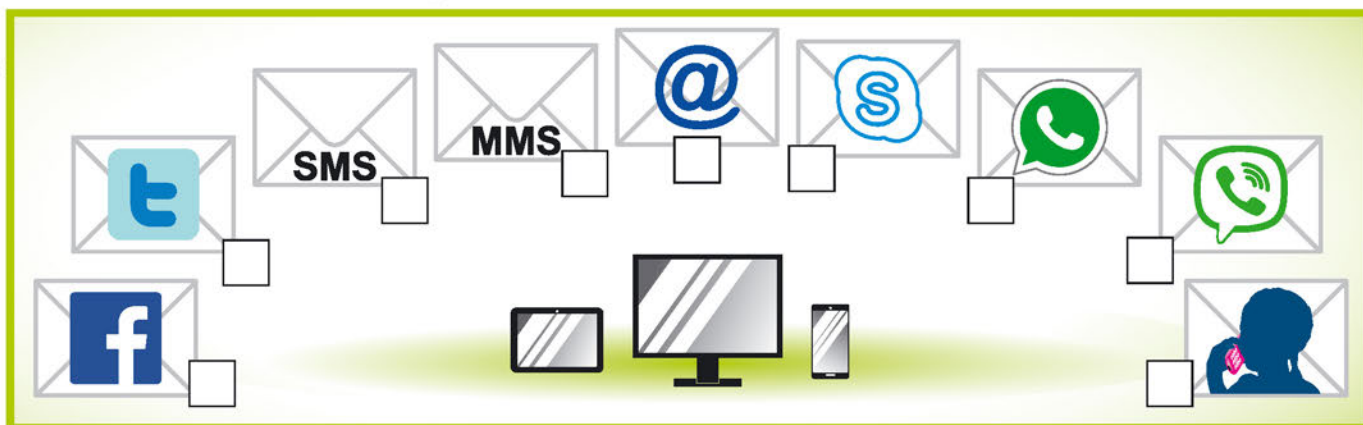

Разкажи и обясни защо показаните начини и места за използване на мобилен телефон са неприемливи, неправилни, непозволенни или опасни.



Шифровъчен кръг

МАТЕРИАЛИ И ИНСТРУМЕНТИ

- приложение № 21
- ножица
- ос



Направи шифровъчен кръг за кодиране и декодиране на тайни съобщения.

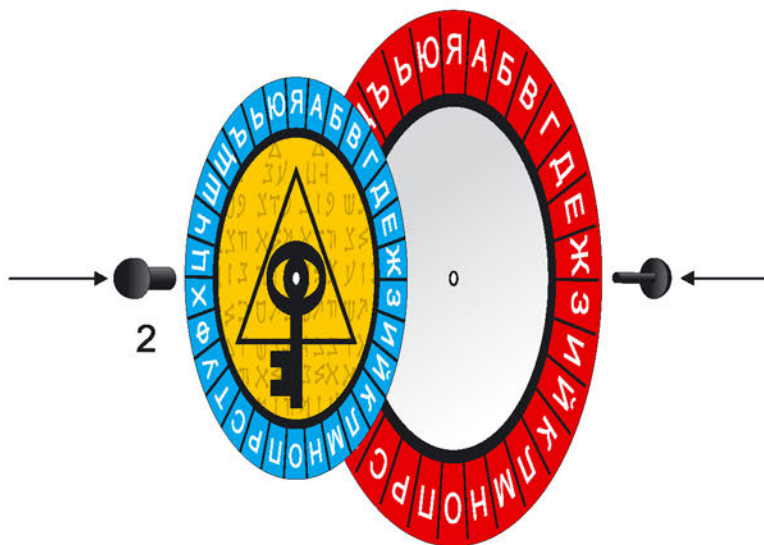
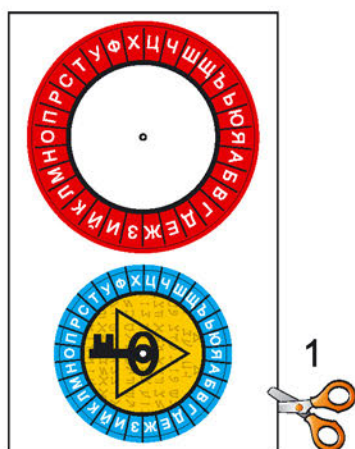

Разкодирай с код М съобщението: ОСЯСЧМ ОМЦМЩДФЛ



Кодирай с код Я съобщението: СЛЪНЧЕВО ЛЯТО





1. Свържи всяка играчка и модел със съответния начин на задвижване.



човек

вода

вятър

електричество

2. Отбележи със знак „✓“ ползата от приложението на колело и ос в техниката и бита.



по-лесно

по-бързо

по-далече

3. Свържи показаните предмети със съответните наименования.

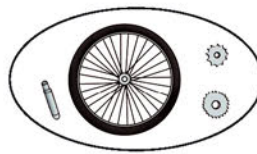

части

механизъм

машина

4. Огради правилните и безопасни начини за работа с инструментите и материалите.

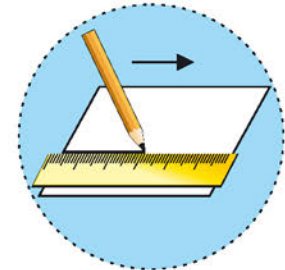
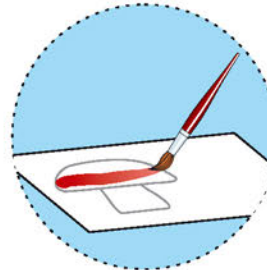
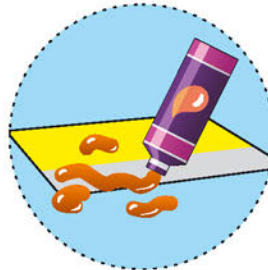
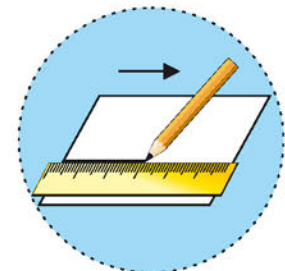
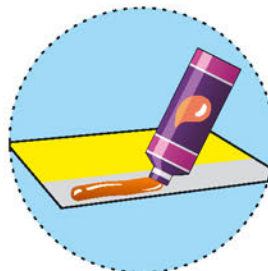

Вече знам и мога

5. Напиши номерата на операциите за изработване на пролетна картичка по реда на тяхното извършване.



6. Свържи наименованията на операциите със съответните картинки.

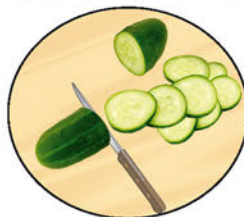

почистване

измиване

смесване

нарязване

7. Напиши номерата на дейностите по реда на извършването им при работа по проект.

- Представяне на резултатите
- Оценяване
- Изработване и тестване на изделието
- Избиране на материали и инструменти
- Разпределяне на задачите и поставяне на срокове
- Проучване, събиране на информация

8. Свържи наименованията на грижите със съответните картинки.



поливане

разрохкване

укрепване

почистване

9. Свържи наименованията на грижите със съответните картинки.



разресване

лекуване

хранене

разхождане

Вече знам и мога



10. Свържи показаните професии със съответните инструменти, уреди и машини.



11. Отбележи с буквата „с“ обектите, в които се продават стоки, а с буквата „у“ – обектите, в които се предлагат услуги.



12. Огради всяка стока със съответния цвят.

ХРАНИТЕЛНИ СТОКИ

СПОРТНИ СТОКИ



13. Свържи показаните изделия със съответните технически рисунки.

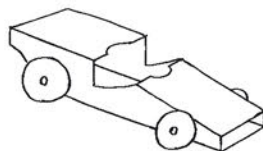
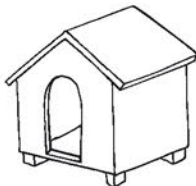
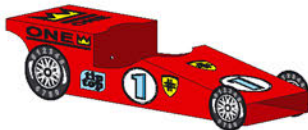

Тодорка Николова Николова
Силвия Маркова Гърневска
Светла Костова Ананиева
Валентин Георгиев Ананиев

ТЕХНОЛОГИИ И ПРЕДПРИЕМАЧЕСТВО

за първи клас



е-учебник
на agpc
www.bititechnika.com